

Lecture 6: Light and Lighting Design

6.1 Introduction

Light is a form of electromagnetic radiation. It is similar in nature and behaviour to radio waves at one end of the frequency spectrum and X-rays at the other. Light is reflected from a polished (specular) surface at the same angle that strikes it. A matt surface reflects in a number of directions and a semi-matt surface responds somewhere between a polished and a matt surface.

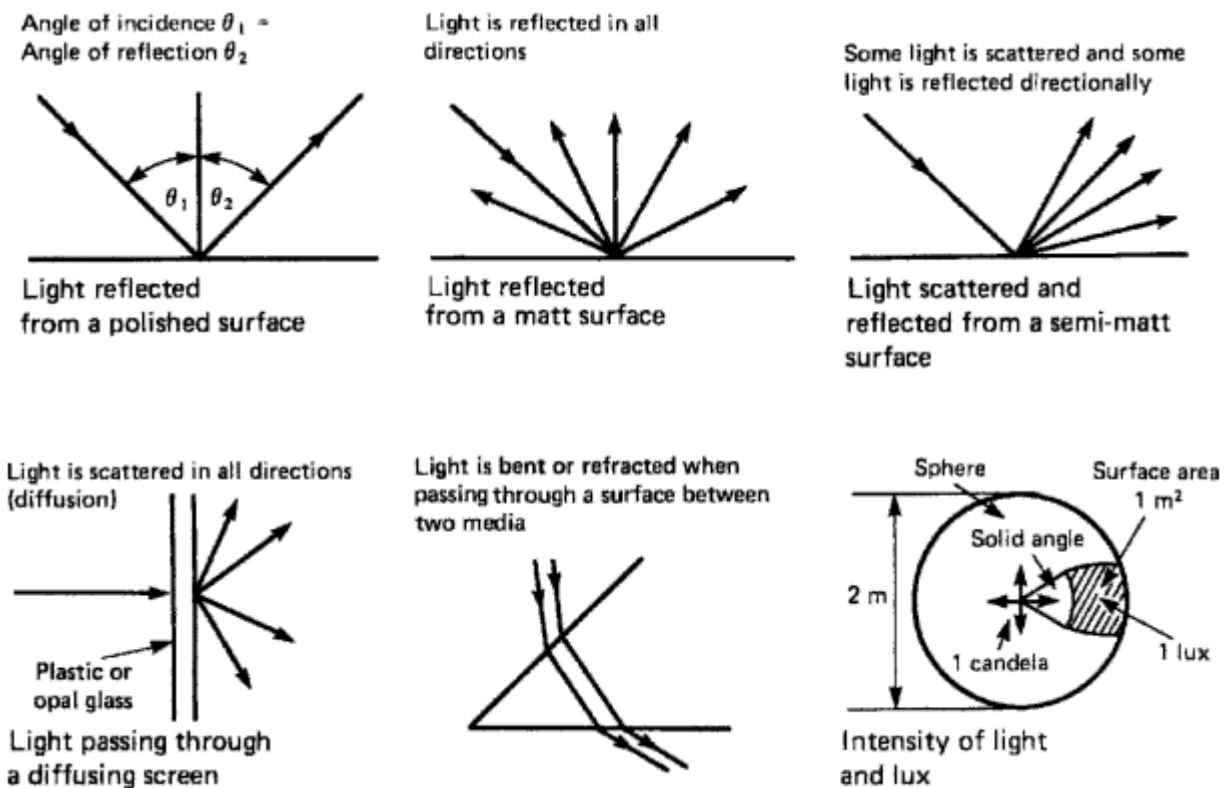

FIGURE 6.1: Light reflection from different surfaces.

6.2 Light Effects.

1. Visual functions

- Illumination of task area in conformity with relevant standards – glare-free and convenient

2. Creating biological effects

- Supporting people's biological rhythms
- Stimulating and motivating

3. Emotional perception

- Pleasant lighting enhancing the interior design.
- Makes people relax and feel at ease.

6.3 Lighting Terminologies

The luminous flux

- Describes the quantity of light emitted by a light source. It is measured in lumens (lm).

The luminous efficiency

- Is the ratio of the luminous flux to the electrical power consumed (lm/W). It is also called efficacy.

The luminous intensity

- Describes the quantity of light that is radiated in a particular direction. This is a useful measurement for directive lighting elements such as reflectors. It is represented by the luminous intensity distribution curve (LDC). It is measured in Candela (cd).

Illuminance.

- Describes the quantity of luminous flux falling on a surface. It decreases by the square of the distance (inverse square law). Relevant standards specify the required illuminance. It is measured in Lux (lx).

$$E(lx) = \frac{\text{luminous flux}(lm)}{\text{area}(m^2)}$$

(6.1)

Luminance

- It specifies the brightness of a surface and is essentially dependent on its reflectance (finish and colour). It is the only basic lighting parameter that is perceived by the eye.

Its unit of measurement is cd/m^2

6.4 Quality characteristics of lighting

- Personal Control
- Energy Efficiency
- Daylight integration
- Appropriate colour rendition
- Glare Limitation
- Sufficient illumination level
- Appropriate colour rendition
- Harmonious brightness distribution
- Light as an interior design element.

6.5 Light colour

It describes the colour appearance of the light. It sets the underlying mood of the environment/room

Table 6.1 Light colour

Colour temperature	Appearance	Association
2000K	Yellow	Yellow
3000 K	reddish	Warm White(ww)
3500 K	white	Intermediate(nw)
4200K	Cool White	Cool White
above 5,300 K	blue-ish	Cool(tw)
6500K	(Cool)day light	(Cool)day light

NB. Ww = warm white, nw = intermediate, tw = cool white

Kelvin (k) = *Kelvin(K)*, $K = 0^{\circ} + 273$

6.6 Energy Control

The following factors have a positive impact on the reduction of energy consumption:

- Sensible control of lighting
- Use of daylight
- Use of presence detectors
- Intelligent consideration of hours of use
- Energy-efficient lamps
- Need-based use of luminaires and lighting solutions, specified for the respective application.
- Constant lighting control (maintenance control)

6.7 Types of Lighting Lamps

Filament lamps -the tungsten iodine lamp is used for flood lighting. Evaporation from the filament is controlled by the presence of iodine vapour. The gas-filled, general-purpose filament lamp has a fine tungsten wire sealed within a glass bulb. The wire is heated to incandescence (white heat) by the passage of an electric current.

Discharge lamps-these do not have a filament, but produce light by excitation of a gas. When voltage is applied to the two electrodes, ionization occurs until a critical value is reached when current flows between them. As the temperature rises, the mercury vaporizes and electrical discharge between the main electrodes causes light to be emitted.

Fluorescent tube -this is a low pressure variation of the mercury discharge lamp. Energized mercury atoms emit ultra-violet radiation and a blue/green light. The tube is coated internally with a fluorescent powder which absorbs the ultra-violet light and reradiates it as visible light.

High pressure sodium discharge lamps produce a consistent golden white light in which it is possible to distinguish colours. They are suitable for floodlighting, commercial and industrial lighting and illumination of highways. The low pressure variant produces light that is virtually

monochromatic. The colour rendering is poor when compared to the high pressure lamp. Sodium vapour pressure for high and low pressure lamps is 0.5 Pa and 33 kPa, and typical efficacy is 125 and 180 lm/W respectively.

Compact Fluorescent Lamps:

Compact fluorescent lamps are a smaller variation and development of the standard fluorescent tube fitting. They are manufactured with conventional bayonet or screw fittings. Unit cost is higher than tungsten filament bulbs but will last over 8000 hours, consuming only about 25% of the energy of a conventional bulb. Tungsten filament bulbs have a life expectancy of about 1000 hours. The comfort type produces gentle diffused light and is suitable where continuous illumination is required. The prismatic types are more robust and are suitable for application to workshops and commercial premises. Electronic types are the most efficient, consuming only 20% of the energy that would be used in a tungsten filament bulb. Compact fluorescent lamps are not appropriate for use with dimmer switches.

Light Emitting Diodes (LEDs).

LED stands for: Lighting Emitting Diodes.

Diode:

Is a semiconductor device that allows current to pass through in one direction only.

Light Emitting:

Once current passes through, the diode emits light.

Advantages of LED (**Advances in LED technologies**)

6.8 Light Fittings

Fittings for lighting may be considered in three categories:

1. **General utility** - designed to be effective, functional and economic.
2. **Special** - usually provided with optical arrangements such as lenses or reflectors to give directional lighting.
3. **Decorative** - designed to be aesthetically pleasing or to provide a feature, rather than to be functional.

From an optical perspective, the fitting should obscure the lamp from the discomfort of direct vision to reduce the impact of glare.

6.9 Luminaires

Luminaire -a word to describe the complete lighting unit including the lamp. When selecting a lamp type, it is important to select a luminaire to complement the lamp both functionally and aesthetically.

A luminaire has several functions: it defines the lamp position, protects the lamp and may contain the lamp control mechanism.

In the interests of safety, it must be well insulated, in some circumstances resistant to moisture, have adequate appearance for purpose and be durable.

6.10 Lighting Switching Circuits

Lighting circuits can incorporate various switching arrangements.

- **One-way switch circuit:** The single-pole switch must be connected to the live conductor. To ensure that both live and neutral conductors are isolated from the supply a double-pole switch may be used, although these are generally limited to installations in larger buildings where the number and type of light fittings demand a relatively high current flow. Provided the voltage drop (4% max.,) is not exceeded, two or more lamps may be controlled by a one-way single-pole switch.
- **The two-way switch:** In principle, it is a single-pole changeover switch interconnected in pairs. Two switches provide control of one or more lamps from two positions, such as that found in stair/landing, bedroom and corridor situations. In large buildings, every access point should have its own lighting control switch. Any number of these may be incorporated into a two-way switch circuit. These additional controls are known as **intermediate switches**.

6.11 Lighting Circuits

Lighting circuits can incorporate various switching arrangements. In a one-way switch circuit, the single-pole switch must be connected to the live conductor. To ensure that both live and neutral conductors are isolated from the supply a double-pole switch may be used, although these are

generally limited to installations in larger buildings where the number and type of light fittings demand a relatively high current flow.

In principle, the two-way switch is a single-pole changeover switch interconnected in pairs. Two switches provide control of one or more lamps from two positions, such as that found in stair/landing, bedroom and corridor situations. In large buildings, every access point should have its own lighting control switch. Any number of these may be incorporated into a two-way switch circuit. These additional controls are known as intermediate switches.

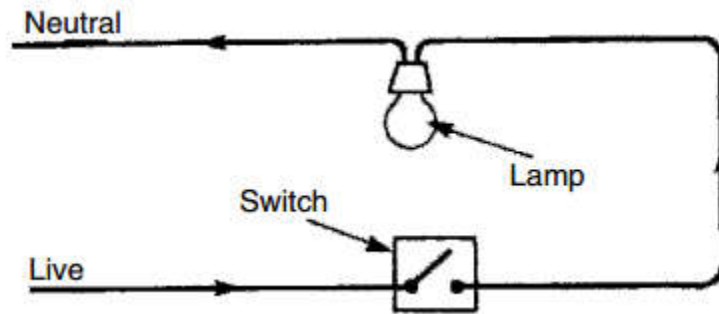

FIGURE 6.2:One-way single-pole switch circuit controlling one lamp.

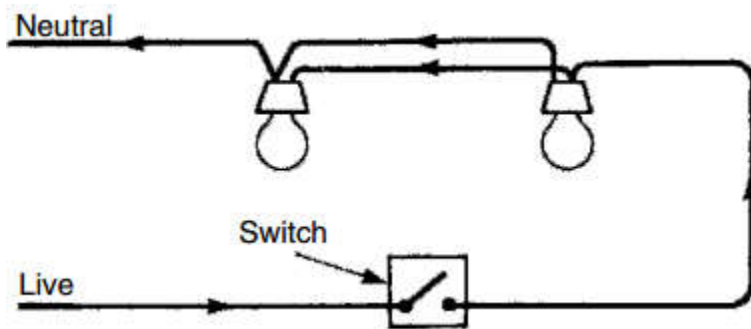

FIGURE 6.3:One-way single-pole switch circuit controlling two or more lamps.

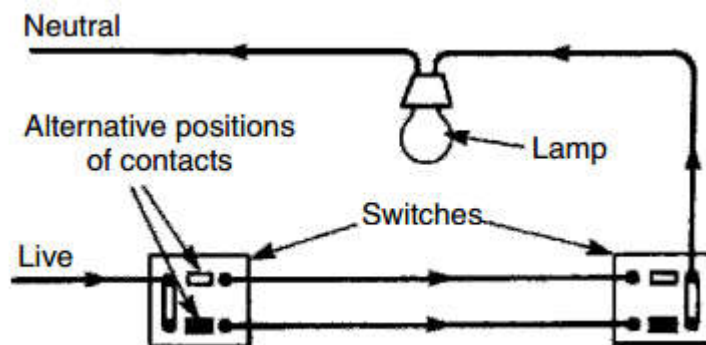

Figure 6.4 Two-way switching

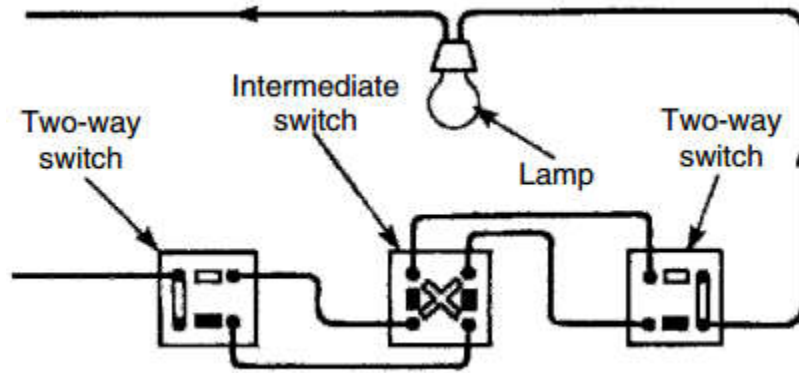

FIGURE 6.5: Two-way switching with one intermediate switch

The Master Switch

The purpose of a 'master' switch is to limit or vary the scope of control afforded by other switches in the same circuit. If a 'master' switch (possibly one with a detachable key option) is fixed near the main door of a house or flat, the householder is provided with a means of controlling all the lights from one position.

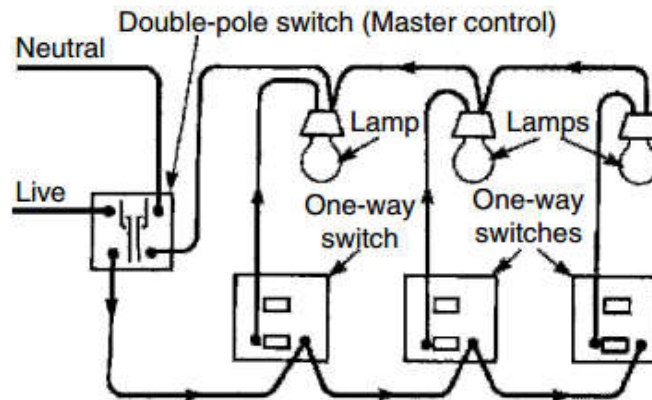

FIGURE 6.6 'Master' control wiring circuit

A sub-circuit for lighting is generally limited to a total load of 10, 100-watt light fittings. It requires a 5-amp fuse or 6-amp mcb overload protection at the consumer unit.

6.12 Emergency lights

Many buildings must have some form of emergency lighting to come on if the electric supply to the ordinary lights fails. BS 5266: Emergency lighting, BS EN 1838, BS 5266-7: Lighting applications. Emergency lighting are the codes of practice to which to refer.

One of the possible causes of failure is a breakdown in the supply authority's service to the building and, therefore, the emergency supply must be independent of the service into the building.

Electric lighting for emergency use can be provided if the building has a standby generator.

A generator can be installed to take over the entire supply to a building, so that the only special provision for emergency lights need made is to cover the time between the mains supply fails and the standby generator is up to speed, but for economy the standby generator is often rated at less than the ordinary mains service to the building.

The distribution then has to be arranged so that only a part of the service within the building is fed by the generator, and only a few of the lights should be included in this part. There is no need for full lighting under emergency conditions, and lighting in the main corridors and staircases is usually enough. High-risk task areas need special consideration.

Emergency supplies are of particular importance in hospitals and no new hospital should be built without a standby generator, but buildings like schools, offices, theatres and blocks of flats seldom justify the expense. For these buildings, emergency lighting is almost invariably provided, by self-contained battery luminaires.

Emergency lights are fitted throughout the building. They come on only when the mains fail (a non-maintained system) and cannot be used while the mains are healthy.

They are not intended to give full illumination, but only.

6.12 Lighting Design Methods

Lumen Method of Lighting Design

The lumen method of lighting design is used to determine a lighting layout that will provide a design maintained illuminance. It is valid if the luminaires are mounted above the working plane in a regular pattern. The method uses the formula:

$$N = \frac{E \times A}{\Phi_n \times n \times M_f \times U_f} \quad (6.2)$$

Where:

E = Average recommended illuminance (Lux) in Lumens/m²

A = Area of the working plane (m²)

Φ_n = Nominal Lamp Luminous Flux

M_f = Maintenance factor

U_f = Utilization factor

N = Number of Luminaires

n = No. of luminaire's lamps

Utilization factor (U_f).

It is the ratio of the lumens received on the working plane to the total flux output of lamps in the scheme. This represents the proportion of luminous flux of the lamp that reaches the working plane and is dependent on the following:

- Luminaire efficiency
- Lighting fitting distribution
- Reflectance of the room surfaces i.e. (Ceiling, walls and floor)
- Room index.

The room index represents the geometrical ratio of the area of the horizontal surfaces to that of the Vertical surfaces measured from the working plane in the room and is expressed as:

$$R_i = \frac{(LXW)}{H_m(L + W)} \quad (6.3)$$

Where: L = Length of the room

W = Width of the room

H_m = Height of the Luminaire above the working plane.

The room reflectance depends on the room surface finishes. For example if the ceiling is painted white, floor is terrazzo/pvc tiles and the walls are painted white. The design reflectance ratio used can be say, C: W: F = 0.8: 0.6: 0.2.

Standard photometric tables for a combination of various values of room indices and surface reflectance exist (given by manufacturers) from which the value of the utilization factor (U_f) can be obtained directly or extrapolated for values of room indices that are not integers.

The following formula can be used.

$$U_f = U_{f(L)} + \frac{\{(R_i - R_{i(L)})(U_{f(U)} - U_{f(L)})\}}{(R_{i(U)} - R_{i(L)})} \quad (6.4)$$

Where U=Upper.

L=Lower.

Maintenance factor (M_f)

This gives the proportion of illuminance provided by a luminaire in normal working conditions (dirty conditions) of both the luminaire and the room surfaces to the illuminance of the same luminaire in clean conditions.

Say if expect that the room surfaces will be maintained most of the times, a typical maintenance factor will be 0.85.

Nominal Lamp Luminous Flux (Φ_n)

These values can be obtained from lamp photometric data usually provided by manufacturers in the catalogues.

Illumination level (E)

These can be obtained from a chart guide used for obtaining recommended illuminance (Lux) prepared by the Chartered Institute of Building Services Engineers (CIBSE) and the Philips Lighting design Manual. These values entirely depend on the type of use the room is put to.

Table: 6.2 Recommended Typical Illumination Levels.

Assuming you are working on a Hospital building project.

a) Hospital

Item	Description	Recommended Lux (E) in Lumens/M²
1.0	<u>Corridors</u> : Night	50
	Daytime/ Evening	200
2.0	<u>Wards</u> : Circulation at night	30
	Observation at night	5
	General Lighting	150
	Simple Examination/Reading	300
3.0	<u>Examination Rooms</u> : General Lighting	500
	Local Examination Lighting	1000
4.0	<u>Intensive therapy</u> : Bedhead	50
	Observation	750

5.0	<u>Nurses Stations</u>	300
6.0	<u>Operating Theaters: Pre-Op room</u>	500
	General theater lighting	1000
	Local	100,000
7.0	<u>Laboratories & Pharmacies: General Lighting</u>	750
	Local	1000
8.0	<u>Consulting Rooms: General Lighting</u>	500
	Local	750
9.0	<u>Autopsy Rooms: General Lighting</u>	750
	Local	5000

b) **Offices**

Item	Description	Recommended Lux E in Lumens/M²
1.0	General offices with typing, computers etc.	500
2.0	Conference rooms	300
3.0	Archives	200

c) **General Building areas**

Item	Description	Recommended Lux E in Lumens/M²
1.0	Circulation areas, corridors	100
2.0	Cloak rooms, toilets	100
3.0	Stores, Stock rooms	100
4.0	Stairs, escalators	150

d) **Kitchen Block**

Item	Description	Recommended Lux E in Lumens/M²
1.0	Servery	300

2.0	Kitchen	500
3.0	Food stores	150
4.0	Food preparation area	500
5.0	Cold store	300
6.0	Office	500
7.0	Kitchen yard	30

e) **Laundry Block**

Item	Description	Recommended Lux E in Lumens/M ²
1.0	Pressing	500
2.0	Sewing/Mending	750
3.0	Gents/Ladies	100

f) **Workshop Block**

Item	Description	Recommended Lux E in Lumens/M ²
1.0	Welding	300
2.0	Machine work, coil winding	500
3.0	Fine bench & Machine work	750
4.0	Testing/ adjusting Electrical components	1000

Spacing-to-height ratio (SHR) is the center-to-center (S) distance between adjacent luminaires to their mounting height (H) above the working plane. Manufacturers' catalogues can be consulted to determine maximum SHRs, e.g. a luminaire with trough reflector is about 1.65 and an enclosed diffuser about 1.4.

Method of spacing fluorescent tubes

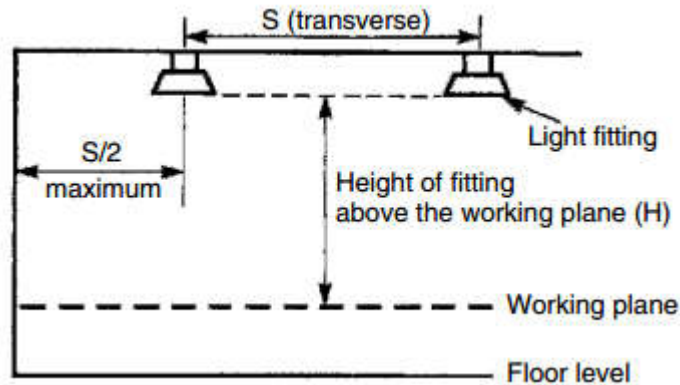

6.7 (a) Vertical section of a room

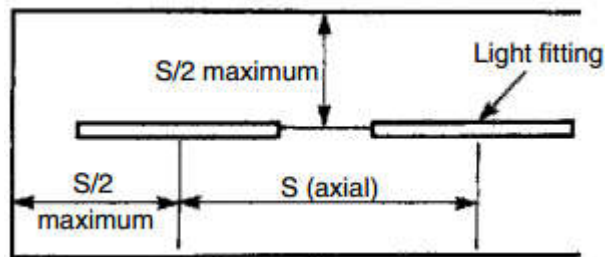

6.7 (b) Plan of a room

Example 6.1: Taking a typical Project.

1. A Rectangular Room.

Given a typical rectangular room with the following dimensions as:

- Length of the room, $L = 5\text{m}$
- Width of the room, $W = 5.8\text{m}$
- Room Height, $H=2.05\text{m}$

Steps:

- First, determine the design illuminance for the room.
- For this offices, the design illuminance E is = 500 Lux as the lighting requirements are for an offices.

- Choose the design luminaire:
- Choosing the luminaire as **2x58w, 1500mm HPF fluorescent fitting** with low brightness louvers as Thorn, which prevents a direct or reflected view of the fluorescent tubes.
- For this fitting, the nominal luminous flux $\Phi_n = 5400$ lumens per lamp.

Height of the luminaire above the working plane $H_m = 2.05\text{m}$

Thus the room index, R_i

$$R_i = \frac{L \times W}{H_m(L + W)}$$

$$R_i = \frac{5 \times 5.8}{2.05(5 + 5.8)} = 1.31$$

From the photometric tables, and by extrapolation, the utilization factor is obtained as:

$$U_f = 0.52 + \frac{(1.31 - 1.0)(0.58 - 0.52)}{(2.0 - 1.0)} = 0.54$$

The number of luminaires is given as;

$$n = \frac{A \times E}{U_f \times M_f \times \Phi_n}$$

$$= \frac{5 \times 5.8 \times 500}{0.54 \times 0.85 \times 2 \times 5400} = 2.92$$

n is taken as 3 No. 2x58w, 1500mm HPF fluorescent fittings.

This gives an illuminance of

$$E = n \times \frac{U_f \times M_f \times \Phi_n}{A}$$

$$= 3 \times \frac{0.54 \times 0.85 \times 2 \times 5400}{5 \times 5.8} = 512.81 \text{ Lux.}$$

This level of illumination is acceptable, as the luminaires will therefore provide adequate lighting for the room.

Example 6.2

Example. An office 8 m long by 7 m wide requires an illumination level of 400 lux on the working plane. It is proposed to use 80 W fluorescent fittings having a rated output of 7375 lumens each. Assuming a utilization factor of 0.5 and a maintenance factor of 0.8 design the lighting scheme.

$$n = \frac{A \times E}{U_f \times M_f \times \Phi_n}$$

$$n = \frac{8 \times 7 \times 400}{0.5 \times 0.8 \times 7375} = 7.59, \text{ use } 8 \text{ fittings}$$

