

LECTURE 1: Electric Circuit Theory

1.1 Introduction

Technology is rapidly changing the way we do things; we now have computers in our homes, electronic control systems in our cars, cellular phones that can be used just about anywhere, robots that assemble products on production lines, and so on.

A first step to understanding these technologies is electric circuit theory.

Circuit theory provides you with the knowledge of basic principles that you need to understand the behavior of electric and electronic devices, circuits, and systems.

As an example, consider Figure 1.1 below, which shows a basic Radio receiver system.

Its design is based on electrical, electronic, and magnetic circuit principles. For example, resistors, capacitors, transistors, and integrated circuits are used to control the voltages and currents that operate its motors and amplify the audio and video signals that are the heart of the system. A magnetic circuit, the power transformer, transforms the ac voltage from the 240-volt wall outlet voltage to the lower voltages required by the system.



Figure 1.1: A Radio receiver is a familiar example of an electrical/electronic system.

Its applications are all rooted in the principles of circuit theory.

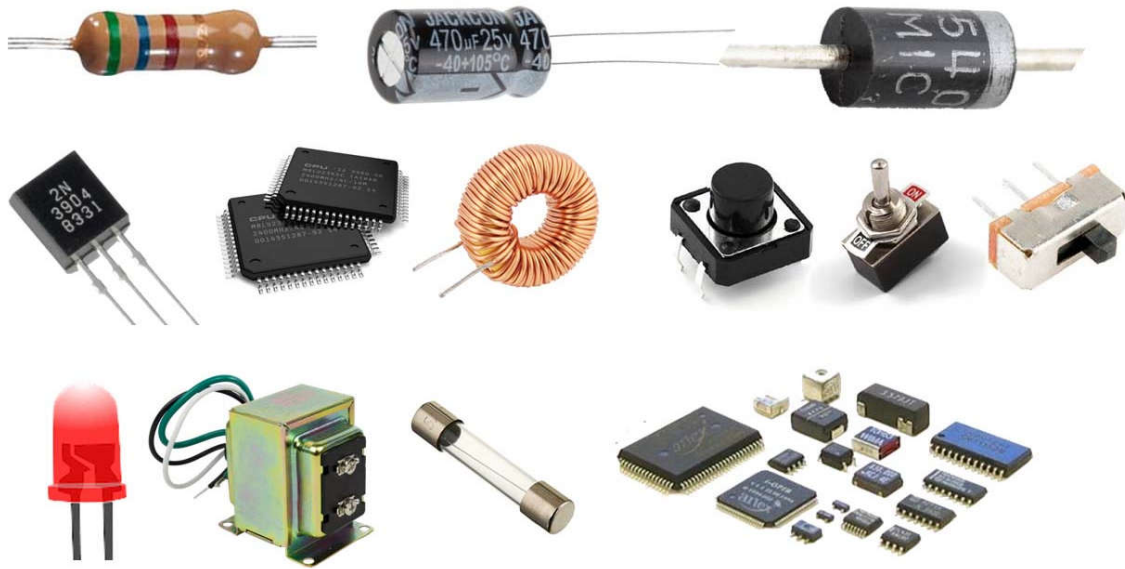

Figure 1.2: Some typical electronic/electrical components.

1.2 Units associated with basic electrical quantities

Very early units of measurement were based on the things easily available – the length of a stride, the distance from the nose to the outstretched hand, the weight of a stone and the time-lapse of one day. Over the years, new units were introduced and old ones modified. Different branches of science and engineering were working in isolation, using their own units, and the result was an overwhelming variety of units. In all branches of science and engineering there is a need for a practical system of units which everyone can use. In 1960, the General Conference of Weights and Measures agreed to an international system called the *Système International d’Unités* ((abbreviated to **SI units**)).

SI units

The system of units used in engineering and science is the *Système Internationale d’Unités* (International system of units), usually abbreviated to ‘SI units, It is based on the metric system. SI units are based upon a small number of fundamental units from which all other units may be derived. Table 1.1 describes some of the basic units we shall be using in our electrical studies.

Like all metric systems, SI units have the advantage that prefixes representing various multiples or submultiples may be used to increase or decrease the size of the unit by various powers of 10. Some of the more common prefixes and their symbols are shown in Table 1.2.

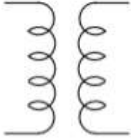

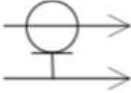









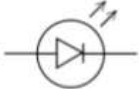

Table 1.1 Basic SI units

Quantity	Measure of	Basic Unit	Symbol	Notes
Area	Length x length	Metre squared	m ²	
Current I	Electric current	Ampere	A	
Energy	Ability to do work	Joule	J	Joule is a very small unit 3.6 x 10 ⁶ J = 1 kWh
Force	The effect on a body	Newton	N	
Frequency	Number of cycles	Hertz	Hz	Mains frequency is 50 Hz
Length	Distance	Metre	m	
Mass	Amount of material	Kilogram	Kg	One metric tonne =1000 kg
Magnetic flux Φ	Magnetic energy	Weber	Wb	
Magnetic flux density B	Number of lines of magnetic flux	Tesla	T	
Potential or pressure	Voltage	Volt	V	
Period T	Time taken to complete one cycle	Second	s	The 50 Hz mains supply has a period of 20ms
Power	Rate of doing work	Watt	W	
Resistance	Opposition to current flow	Ohm	Ω	
Resistivity	Resistance of a sample piece of material	Ohm metre	ρ	Resistivity of copper is 17.5x10 ⁻⁹ Ωm
Temperature	Hotness or coldness	Kelvin	K	0°C = 273 K. A change of 1 K is the same as 1°C
Time	Time	Second	s	60 s = 1 min 60 min = 1 h
Weight	Force exerted by a mass	Kilogram	kg	1000 kg = 1 tonne

Table 1.2 Symbols and multiples for use with SI units

Prefix	Symbol	Multiplication factor		
Mega	M	10 ⁶	or	1,000,000
Kilo	k	10 ³	or	1000
Hecto	h	10 ²	or	100
Deca	da	10	or	10
Deci	d	10 ⁻¹	or	÷10
Centi	c	10 ⁻²	or	÷100
Milli	m	10 ⁻³	or	÷1000
Micro	μ	10 ⁻⁶	or	÷1,000,000

1.3 Typical Standard symbols for electrical components

	Ground or Earth Electrode		Transformer
	Antenna		Coaxial Plug
	Battery: Single Cell		Switch
	Source: Constant Voltage		Resistor
	Fuse		Capacitor
	Inductor		Diode
	Motor		Diode LED
	Bulb		

1.4 Potential difference and resistance, and current.

The drift of electrons within a conductor is known as an **electric current**, measured in amperes and given the symbol I .

For a current to continue to flow, there must be a complete circuit for the electrons to move around. If the circuit is broken by opening a switch, for example, the electron flow and therefore the current will stop immediately.

To cause a current to flow continuously around a circuit, a driving force is required, just as a circulating pump is required to drive water around a central heating system. This driving force is the *electromotive force* (e.m.f.). Each time an electron passes through the source of e.m.f., more energy is provided to send it on its way around the circuit.

An e.m.f. is always associated with energy conversion, such as chemical to electrical in batteries and mechanical to electrical in generators. The energy introduced into the circuit by the e.m.f. is transferred to the load terminals by the circuit conductors.

The **potential difference** (p.d.) is the change in energy levels measured across the load terminals. This is also called the volt drop or terminal voltage, since e.m.f. and p.d. are both measured in volts. **Resistance** in every circuit offers some opposition to current flow, which we call the circuit *resistance*, measured in ohms (symbol Ω), to commemorate the famous German physicist **Georg Simon Ohm**, who was responsible for the analysis of electrical circuits. As already mentioned above, for a continuous current to flow between two points in a circuit a potential difference (p.d.) or voltage, V , is required between them; a complete conducting path is necessary to and from the source of electrical energy. The unit of p.d. is the volt, V .

Current flow, by convention, is considered as flowing from the positive terminal of the cell, around the circuit to the negative terminal.

1.5 Basic electrical measuring instruments

The type of instrument to be purchased for general use in the electrical industries is a difficult choice because there are so many different types on the market and every manufacturer's representative is convinced that his company's product is the best. However, most instruments can be broadly grouped under two general headings: those having *analogue* and those with *digital* displays.

Analogue meters or instruments

Analogue meters have a pointer moving across a calibrated scale. They are the only choice when a general trend or variation in value is to be observed. Hi-fi equipment often uses analogue displays to indicate how power levels vary with time, which is more informative than a specific value. Red or danger zones can be indicated on industrial instruments. The fuel gauge on a motor car often

indicates full, half-full or danger on an analogue display which is much more informative than an indication of the exact number of litres of petrol remaining in the tank



Figure 1.3 Analogue Multimeter

These meters are only accurate when used in the calibrated position – usually horizontally. Most meters using an analogue scale incorporate a mirror to eliminate parallax error. The user must look straight at the pointer on the scale when taking readings and the correct position is indicated when the pointer image in the mirror is hidden behind the actual pointer. That is the point at which a reading should be taken from the appropriate scale of the instrument.

Digital meters or instruments

Digital meters provide the same functions as analogue meters but they display the indicated value using a seven-segment LED to give a numerical value of the measurement. Modern digital meters use semiconductor technology to give the instrument a very high-input impedance, typically about 10 MΩ, and, therefore, they are ideal for testing most electrical or electronic circuits.



Figure 1.4 Digital multimeter suitable for testing electrical and electronic **circuits**

The choice between an analogue and a digital display is a difficult one and must be dictated by specific circumstances. However, if you are an electrician or service engineer intending to purchase a new instrument, I think on balance that a good-quality digital multimeter such as that shown in Fig. 1.4 would be best.

Having no moving parts, digital meters tend to be more rugged and, having a very high-input impedance, they are ideally suited to testing all circuits that an electrician might work on in their daily work.

An Ammeter

An ammeter is an instrument used to measure current and must be connected in series with the circuit.

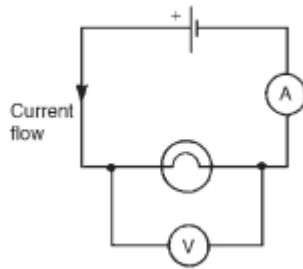

Figure 1.5

Figure 1.5 shows an ammeter connected in series with the lamp to measure the current flowing through it.

Voltmeter

A **voltmeter** is an instrument used to measure potential difference and must be connected in parallel with the part of the circuit whose potential difference is required. To avoid a significant current flowing through it a voltmeter must have a very high resistance.

Ohmmeter

An **ohmmeter** is an instrument for measuring resistance.

A multimeter, or universal instrument, may be used to measure voltage, current and resistance.

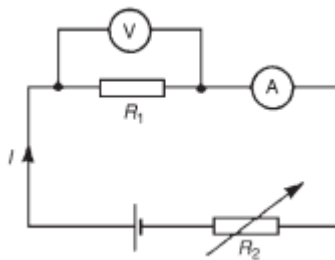

Figure 1.6

The multimeter

Multimeters are designed to measure voltage, current or resistance. Before taking measurements the appropriate volt, ampere or ohm scale should be selected. To avoid damaging the instrument it is good practice first to switch to the highest value on a particular scale range. For example, if

the 10A scale is first selected and a reading of 2.5 A is displayed, we then know that a more appropriate scale would be the 3 A or 5 A range. This will give a more accurate reading which might be, say, 2.49 A. When the multimeter is used as an ammeter to measure current it must be connected in series with the test circuit, as shown in Fig. 1.7(a). When used as a voltmeter the multimeter must be connected in parallel with the component, as shown in Fig. 1.7(b).

When using a commercial multirange meter as an ohmmeter for testing electronic components, care must be exercised in identifying the positive terminal. The red terminal of the meter, identifying the positive input for testing voltage and current, usually becomes the negative terminal when the meter is used as an ohmmeter because of the way the internal battery is connected to the meter movement. Check the meter manufacturer's handbook before using a multimeter to test electronic components.

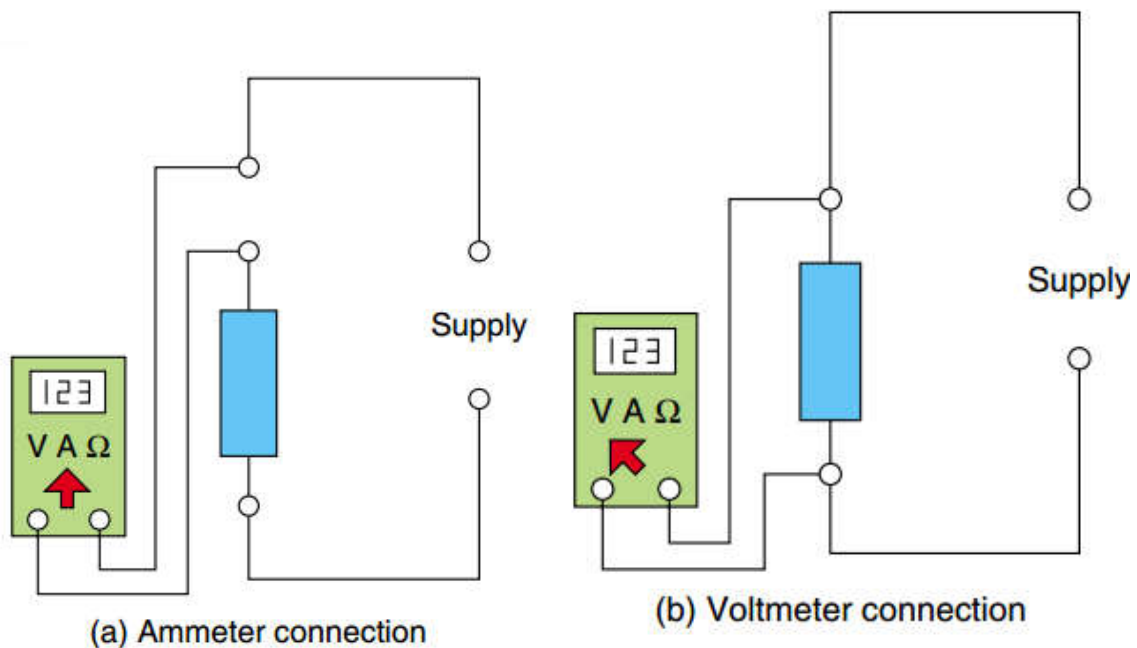

Figure 1.7 Using a multimeter (a) as an ammeter and (b) as a voltmeter

1.6 Ohm's law

In 1826, Georg Simon Ohm published details of an experiment he had done to investigate the relationship between the current passing through and the potential difference between the ends of a wire. As a result of this experiment he arrived at a law, now known as **Ohm's law**, which says

that the current passing through a conductor under constant temperature conditions is proportional to the potential difference across the conductor.

In essence, materials in general have a characteristic behavior of resisting the flow of electric charge. This physical property, or ability to resist current, is known as *resistance* and is represented by the symbol R . The resistance of any material with a uniform cross-sectional area A depends on A and its length L .

$$R = \rho \frac{\ell}{A}$$

Where ρ is known as the resistivity of the material in ohmmeters. Good conductors, such as copper and aluminum, have low resistivities, while insulators, such as mica and paper, have high resistivity. Ohm's law states that the current I flowing in a circuit is directly proportional to the applied voltage V and inversely proportional to the resistance R , provided the temperature remains constant. Thus,

$$I = \frac{V}{R} \text{ or } V = IR \text{ or } R = \frac{V}{I}$$

The resistance R of an element denotes its ability to resist the flow of electric current; it is measured in ohms (Ω).

Resistivity

The resistance or opposition to current flow varies for different materials, each having a particular constant value. If we know the resistance of, say, 1 m of a material, then the resistance of 5 m will be five times the resistance of 1 m. The **resistivity** (symbol ρ – the Greek letter ‘rho’) of a material is defined as the resistance of a sample of unit length and unit cross-section.

Typical values are given in Table 1.3. Using the constants for a particular material we can calculate the resistance of any length and thickness of that material from the equation

$$R = \rho \frac{\ell}{A}$$

Table 1.3 gives the resistivity of silver as $16.4 \times 10^{-9} \Omega \text{m}$, which means that a sample of silver 1 m long and 1 m in cross-section will have a resistance of $16.4 \times 10^{-9} \Omega$.

Table 1.3 Resistivity values

Material	Resistivity (Ωm)
Silver	16.4×10^{-9}
Copper	17.5×10^{-9}
Aluminium	28.5×10^{-9}
Brass	75.0×10^{-9}
Iron	100.0×10^{-9}

Example 1.1

The current flowing through a resistor is 0.8 A when a potential difference of 20 V is applied. Determine the value of the resistance.

From Ohm's law, resistance R

$$\frac{V}{I} = \frac{20}{0.8} = \frac{200}{8} = 25\Omega$$

Currents, voltages and resistances can often be very large or very small. Thus, multiples and sub-multiples of units are often used as shown in Table 1.2 above and below;

Prefix	Name	Meaning	Example
M	mega	multiply by 1 000 000 (i.e., $\times 10^6$)	$2 \text{ M}\Omega = 2\,000\,000 \text{ ohms}$
k	kilo	multiply by 1000 (i.e., $\times 10^3$)	$10 \text{ kV} = 10\,000 \text{ volts}$
m	milli	divide by 1000 (i.e., $\times 10^{-3}$)	$25 \text{ mA} = \frac{25}{1000} \text{ A}$ $= 0.025 \text{ amperes}$
μ	micro	divide by 1 000 000 (i.e., $\times 10^{-6}$)	$50 \text{ }\mu\text{V} = \frac{50}{1\,000\,000} \text{ V}$ $= 0.000\,05 \text{ volts}$

Example 1.2.

Determine the p.d., which must be applied to a 2 k resistor in order that a current of 10 mA may flow.

$$\text{Resistance } R = 2k\Omega = 2 \times 10^3 = 2000\Omega$$

$$\text{Current } I = 10mA = 10 \times 10^{-3}A \text{ or } \frac{10}{10^3} \text{ or } \frac{10}{1000}A = 0.01A$$

$$\text{From Ohm's law, potential difference, } V = IR = (0.01)(2000) = 20V$$

Temperature coefficient

The resistance of most materials changes with temperature. In general, conductors increase their resistance as the temperature increases and insulators decrease their resistance with a temperature increase. Therefore, an increase in temperature has a bad effect on the electrical properties of a material.

Each material responds to temperature change in a different way, and scientists have calculated constants for each material which are called the *temperature coefficient of resistance* (symbol α – the Greek letter ‘alpha’). Table 1.4 gives some typical values.

Table 1.4 Temperature Coefficient Values

Material	Temperature coefficient ($\Omega/\Omega^\circ\text{C}$)
Silver	0.004
Copper	0.004
Aluminium	0.004
Brass	0.001
Iron	0.006

Using the constants for a particular material and substituting values into the following formulae the resistance of a material at different temperatures may be calculated. For a temperature increase from 0°C.

$$R_t = R_0(1 + \alpha t)(\Omega)$$

Where

R_t = the resistance at the new temperature $t^\circ\text{C}$

R_0 = the resistance at 0°C

α = the temperature coefficient for the particular material.

For a temperature increase between two intermediate temperatures above 0°C:

$$\frac{R_1}{R_2} = \frac{(1 + \alpha t_1)}{(1 + \alpha t_2)}$$

Where

R_1 the resistance at the original temperature

R_2 the resistance at the final temperature

α = the temperature coefficient for the particular material.

If we take a 1Ω resistor of, say, copper, and raise its temperature by 1°C, the resistance will increase to 1.004 Ω. This increase of 0.004 Ω is the temperature coefficient of the material.

Example 1.3

The field winding of a D.C. motor has a resistance of 100 Ω at 0°C. Determine the resistance of the coil at 20°C if the temperature coefficient is 0.004 Ω/Ω°C.

$$R_t = R_0(1 + \alpha t)(\Omega)$$

$$R_t = 100\Omega(1 + 0.004 \Omega/\Omega^\circ\text{C} \times 20^\circ\text{C})$$

$$R_t = 100\Omega(1 + 0.08)(\Omega)$$

$$R_t = 108\Omega$$

Example 1.4

The field winding of a shunt generator has a resistance of 150Ω at an ambient temperature of 20°C . After running for some time the mean temperature of the generator rises to 45°C . Calculate the resistance of the winding at the higher temperature if the temperature coefficient of resistance is $0.004 \Omega/\Omega^\circ\text{C}$.

$$\frac{R_1}{R_2} = \frac{(1 + \alpha t_1)}{(1 + \alpha t_2)}$$
$$\frac{150\Omega}{R_2} = \frac{(1 + 0.004 \Omega/\Omega^\circ\text{C} \times 20^\circ\text{C})}{(1 + 0.004 \Omega/\Omega^\circ\text{C} \times 45^\circ\text{C})}$$
$$\frac{150\Omega}{R_2} = \frac{1.08}{1.18}$$
$$\therefore R_2 = \frac{150\Omega \times 1.18}{1.08} = 164\Omega$$

It is clear from the last two sections that the resistance of a cable is affected by length, thickness, temperature and type of material. Since Ohm's law tells us that current is inversely proportional to resistance, these factors must also influence the current carrying capacity of a cable. The tables of current ratings in Appendix 4 of the IEE Regulations contain correction factors so that current ratings may be accurately determined under defined installation conditions.

1.7 Conductors and insulators

All matter is made up of atoms which arrange themselves in a regular framework within the material. The atom is made up of a central, positively charged nucleus, surrounded by negatively charged electrons. The electrical properties of a material depend largely upon how tightly these electrons are bound to the central nucleus.

A **conductor** is a material in which the electrons are loosely bound to the central nucleus and are, therefore, free to drift around the material at random from one atom to another as shown in Fig. 1.8(a). A conductor is a material having a low resistance, which allows electric current to flow in it. All metals are conductors and some examples include copper, aluminium, brass, platinum, silver, gold and carbon.

An **insulator** is a material in which the outer electrons are tightly bound to the nucleus, so that there are no free electrons to move around the material. An insulator is a material having a high resistance, which does not allow electric current to flow in it. Some examples of insulators include plastic, rubber, glass, porcelain, air, paper, cork, mica, ceramics and certain oils.

If a battery is attached to a conductor as shown in Fig. 1.8(b), the free electrons drift purposefully in one direction only. The free electrons close to the positive plate of the battery are attracted to it since unlike charges attract, and the free electrons near the negative plate will be repelled from it. For each electron entering the positive terminal of the battery, one will be ejected from the negative terminal, so the number of electrons in the conductor remains constant.

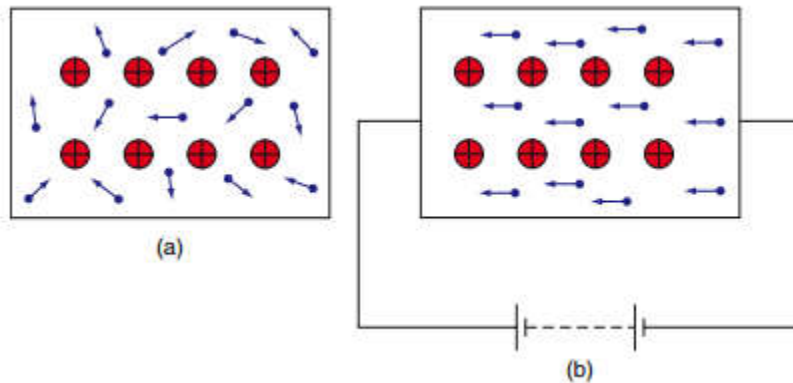

Figure 1.8 Atoms and electrons on a material.

1.8 Electrical power and energy

The product of potential difference V and current I gives power, P in an electrical circuit. The unit of power is the watt, W . Hence;

$$P = V \times I \text{ watts}$$

$$\text{From Ohm's law, } V = IR$$

Substituting for V in equation above gives,

$$P = (IR) \times I$$

$$P = I^2R \text{ watts}$$

Also, from Ohm's law,

$$I = \frac{V}{R}$$

Substituting for I in equation above gives,

$$P = V \times \frac{V}{R}$$

$$P = \frac{V^2}{R} \text{ watts}$$

There are thus three possible formulae, which may be used for calculating power.

Exercise:

A 100 W electric light bulb is connected to a 250 V supply. Determine (a) the current flowing in the bulb, and (b) the resistance of the bulb.

1. 9 Electrical energy

Electrical energy = power × time

If the power is measured in watts and the time in seconds then the unit of energy is watt-seconds or joules.

If the power is measured in kilowatts and the time in hours then the unit of energy is kilowatt-hours, often called the 'unit of electricity'. The 'electricity meter' in the home records the number of kilowatt-hours used and is thus an energy meter.

Example 1.5

A 12 V battery is connected across a load having a resistance of 40Ω. Determine the current flowing in the load, the power consumed and the energy dissipated in 2 minutes.

Current;

$$I = \frac{V}{R} = \frac{12}{40} = 0.3A$$

Power consumed;

$$P = VI = (12)(0.3) = 3.6W$$

$$\text{Energy dissipated} = \text{Power} \times \text{Time} = (3.6 W)(2 \times 60s) = 432J (\text{Since } 1J = 1Ws)$$

1.10. Kirchhoff's laws

(a) **Kirchhoff Current Law.** At any junction in an electric circuit, the total current flowing towards that junction is equal to the total current flowing away from the junction, i.e.

$$\Sigma I = 0$$

$$I_1 + I_2 = I_3 + I_4 + I_5 \text{ or } I_1 + I_2 - I_3 - I_4 - I_5 = 0$$

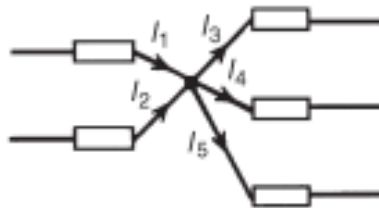

Figure 1.9

(b) **Kirchhoff Voltage Law.** In any closed loop in a network, the algebraic sum of the voltage drops (i.e. products of current and resistance) taken around the loop is equal to the resultant e.m.f. acting in that loop.

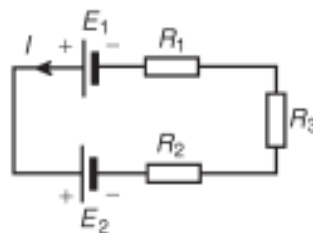

Figure 1.10