

## Lecture 4: Electrical Energy

Energy exists in different forms in nature but the most important form is the electrical energy. The modern society is so much dependent upon the use of electrical energy that it has become a part of our life.

### 4.1 Importance of Electrical Energy

Electrical energy is superior to all other forms of energy due to the following reasons:

- I. **Convenient form.** Electrical energy is a very convenient form of energy. It can be easily converted into other forms of energy. For example, if we want to convert electrical energy into heat, the only thing to be done is to pass electrical current through a wire of high resistance e.g., a heater. Similarly, electrical energy can be converted into light (e.g. electric bulb), mechanical energy (e.g. Electric motors) etc.
- II. **Easy control.** The electrically operated machines have simple and convenient starting, control and operation. For instance, an electric motor can be started or stopped by turning on or off a switch. Similarly, with simple arrangements, the speed of electric motors can be easily varied over the desired range.
- III. **Greater flexibility.** One important reason for preferring electrical energy is the flexibility that it offers. It can be easily transported from one place to another with the help of conductors.
- IV. **Cheapness.** Electrical energy is much cheaper than other forms of energy. Thus, it is overall economical to use this form of energy for domestic, commercial and industrial purposes.
- V. **Cleanliness.** Electrical energy is not associated with smoke, fumes or poisonous gases. Therefore, its use ensures cleanliness and healthy conditions.
- VI. **High transmission efficiency.** The consumers of electrical energy are generally situated quite away from the centres of its production. The electrical energy can be transmitted conveniently and efficiently from the centres of generation to the consumers with the help of overhead conductors known as transmission lines.

### 4.2 Generation of Electrical Energy

The conversion of energy available in different forms in nature into electrical energy is known as generation of electrical energy.

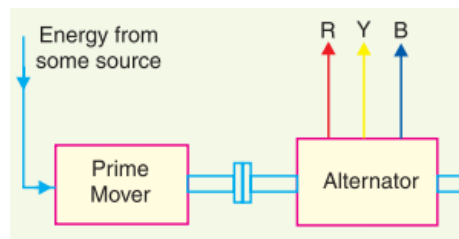

FIGURE 4.1

The generation of electricity in most modern power stations is at 25 kV, and this voltage is then transformed to 400 kV for transmission. Virtually all the generators of electricity throughout the world are three-phase synchronous generators. The generator consists of a prime mover and a magnetic field exciter. The magnetic field is produced electrically by passing a direct current (D.C.) through a winding on an iron core, which rotates inside three-phase windings on the stator of the machine. The magnetic field is rotated by means of a prime mover which may be a steam turbine, water turbine, gas turbine or wind turbine.

### 4.3 Sources of energy

Since electrical energy is produced from energy available in various forms in nature, it is desirable to look into the various sources of energy. These sources of energy are:

- (I). The Sun
- (II). The Wind
- (III). Water
- (IV). Fuels
- (V). Nuclear energy.

Out of these sources, the energy due to Sun and wind has not been utilized on large scale due to a number of limitations. At present, the other three sources viz., water, fuels and nuclear energy are primarily used for the generation of electrical energy.

#### I. **The Sun.** The Sun is the primary source of energy.

There are two main types of solar energy technology: photovoltaics (PV) and solar thermal. Solar PV is the rooftop solar you see on homes and businesses - it produces electricity from solar energy directly.

Solar thermal technologies use the sun's energy to generate heat, and electricity is generated from that. The heat energy radiated by the Sun can be focused over a small area by means of reflectors. This heat can be used to raise steam and electrical energy can be produced with the help of turbine-alternator combination. However, this method has limited application because:

- It requires a large area for the generation of even a small amount of electric power.
- It cannot be used in cloudy days or at night, it is an uneconomical method.

Nevertheless, there are some locations in the world where strong solar radiation is received very regularly and the sources of mineral fuel are scanty or lacking. Such locations offer more interest to the solar plant builders.



**FIGURE 4.2.** PV system in a domestic situation.

- II. **The Wind.** This method can be used where wind flows for a considerable length of time. The wind energy is used to run the windmill, which drives a small generator. In order to obtain the electrical energy from a windmill continuously, the generator is arranged to charge the batteries. These batteries supply the energy when the wind stops. This method has the advantages that maintenance and generation costs are negligible. However, the drawbacks of this method are
- Variable output,
  - Unreliable because of uncertainty about wind pressure and
  - Power generated is quite small.
- III. **Water.** When water is stored at a suitable place, it possesses potential energy because of the head created. This water energy can be converted into mechanical energy with the help of water turbines. The water turbine drives the alternator, which converts mechanical energy into electrical energy. This method of generation of electrical energy has become very popular because it has low production and maintenance costs. Hydroelectric power stations cover a major share of electricity generation in Kenya.
- IV. **Fuels.** The main sources of energy are fuels viz., solid fuel as coal, liquid fuel as oil and gas fuel as natural gas. The heat energy of these fuels is converted into mechanical energy by suitable prime movers such as steam engines, steam turbines, internal combustion engines etc. The prime mover drives the alternator, which converts mechanical energy into electrical energy. Although fuels continue to enjoy the place of chief source for the generation of electrical energy, yet their reserves are diminishing day by day. Therefore, the present trend is to harness water power, which is more or less a permanent source of power.
- V. **Geothermal Energy.** Geothermal energy is heat derived within the sub-surface of the earth. Water and/or steam carry the geothermal energy to the Earth's surface. Depending on its characteristics, geothermal energy can be used for heating and cooling purposes or be harnessed to generate clean electricity. However, for electricity, generation high or

medium temperature resources are needed, which are usually located close to tectonically active regions. Geothermal energy covers a significant share of electricity demand in Kenya.

- VI. **Nuclear energy.** Towards the end of Second World War, it was discovered that large amount of heat energy is liberated by the fission of uranium and other fissionable materials. It is estimated that heat produced by 1 kg of nuclear fuel is equal to that produced by 4500 tonnes of coal. The heat produced due to nuclear fission can be utilized to raise steam with suitable arrangements. The steam can run the steam turbine, which in turn can drive the alternator to produce electrical energy. However, there are some difficulties in the use of nuclear energy. The principal ones are
- High cost of nuclear plant
  - Problem of disposal of radioactive waste and dearth of trained personnel to handle the plant.

The chief sources of energy used for the generation of electrical energy are water, fuels and nuclear energy. Below is given their comparison in a tabular form:

No.	Particular	Water Power	Fuels	Nuclear Energy
1	Initial cost	High	Low	Highest
2	Running cost	Less	High	Least
3	Reserves	Permanent	Exhaustable	Inexhaustible
4	Cleanliness	Cleanest	Dirtiest	Clean
5	Simplicity	Simplest	Complex	Most Complex
6	Reliability	Most reliable	Less reliable	More reliable

#### 4.4 Unit of electrical energy

**Electrical energy.** The unit of electrical energy is watt-sec or joule and is defined as follows:

One watt-second (or joule) energy is transferred between two points if a p.d. of 1 volt exists between them and 1 ampere current passes between them for 1 second i.e.,

**Electrical energy in watt-sec (or joules) = voltage in volts × current in amperes × time in seconds.**

Joule or watt-sec is a very small unit of electrical energy for practical purposes. In practice, for the measurement of electrical energy, bigger units viz., watt-hour and kilowatt-hour are used.

$$1 \text{ watt-hour} = 1 \text{ watt} \times 1 \text{ hr.}$$

$$= 1 \text{ watt} \times 3600 \text{ sec} = 3600 \text{ watt-sec}$$

$$1 \text{ kilowatt hour (kWh)} = 1 \text{ kW} \times 1 \text{ hr.} = 1000 \text{ watt} \times 3600 \text{ sec} = 36 \times 10^5 \text{ watt-sec.}$$

#### 4.5 Types of fuels

- Solid Fuel: Example, coal.

- Liquid Fuel: Example, Diesel, Petrol.
- Gaseous Fuel: Example, Natural gas, Coal gas.

#### **4.6 Advantages of Liquid Fuels over Solid Fuels**

- I. The handling of liquid fuels is easier and they require less storage space.
- II. The combustion of liquid fuels is uniform.
- III. The solid fuels have higher percentage of moisture and consequently they burn with great difficulty. However, liquid fuels can be burnt with a fair degree of ease and attain high temperature very quickly compared to solid fuels.
- IV. The waste product of solid fuels is a large quantity of ash and its disposal becomes a problem.
- V. However, liquid fuels leave no or very little ash after burning.
- VI. The firing of liquid fuels can be easily controlled. This permits to meet the variation in load demand easily.

#### **4.7 Advantages of Solid Fuels over Liquid Fuels**

- I. In case of liquid fuels, there is a danger of explosion.
- II. Liquid fuels are costlier as compared to solid fuels.
- III. Sometimes liquid fuels give unpleasant odours during burning.
- IV. Liquid fuels require special types of burners for burning.
- V. Liquid fuels pose problems in cold climates since the oil stored in the tanks is to be heated in order to avoid the stoppage of oil flow.

#### **4.8 Electrical Power Supply**

The power supply system is mainly classified into two types,

- Single phase.
- Three-phase system.

The single phase is used in a place where less power is required and for running the small loads. The three phases are used in large industries, factories and in the manufacturing unit where a large amount of power is required.

One of the major difference between the single phase and the three phase is that the single phase consists one conductor and one neutral wire whereas the three-phase supply uses three conductors and one neutral wire for completing the circuit.

## **Definition of Single phase**

The single phase requires two wires for completing the circuit, i.e., the conductor and the neutral. The conductor carries the current and the neutral is the return path of the current. The single phase supplies the voltage up to 230 volts. It is mostly used for running the small appliances like a fan, cooler, grinder, heater, etc.

## **Definition of Three Phase**

The three-phase system consist four wires, three conductors and one neutral. The conductors are out of phase and space  $120^\circ$  apart from each other. The three-phase system is also used as a single-phase system. For the low load, one phase and neutral can be taken from the three-phase supply.

## **Key Differences Between Single Phase and Three Phase**

1. In single-phase supply, the power flows through one conductor whereas the three-phase supply consists three conductors for power supply.
2. The single-phase supply requires two wires (one phase and one neutral) for completing the circuit. The three phase requires three phase wires and one neutral wire for completing the circuit.
3. The single phase supplies the voltage up to 230V whereas the three-phase supply carries the voltage up to 415V.
4. The maximum power is transferred through three phases as compared to single-phase supply.
5. The single phase has two wire, which makes the network simple whereas the three-phase network is complicated as it consists four wires.
6. The single-phase system has only one phase wire, and if the fault occurs on the network, then the power supply completely fails. However, in three-phase system, the network has three phases, and if the fault occurs on any one of the phases, the other two will continuously supply the power.
7. The efficiency of the single-phase supply is less as compared to three-phase supply. Because the three phase supply requires less conductor as compared to single-phase supply for the equivalent circuit.
8. The single-phase supply requires more maintenance and become costly as compared to three-phase supply.
9. The single-phase supply is mostly used in the house and for running the small loads. The three-phase supply is used in large industries and for running the heavy loads.

## **Benefits and Uses of a Single Phase AC Power Supply**

Single-phase power supply units have a broad array of applications. Units that have a limited power need up to 1000 watts typically make the most efficient use of a single-phase AC power supply. Generally, benefits of selecting a single-phase system include:

- Broad array of application uses.
- Most efficient AC power supply for up to 1000 watts.
- Fewer design costs.
- Less complex designs.

## **Benefits and Uses of a Three Phase AC Power Supply**

Typical applications for 3 phase systems include data centers, mobile towers, power grids, shipboard and aircraft, unmanned systems, and any other electronic with a load greater than 1000 watts. Three phase power supplies offer a superior carrying capacity for higher load systems. Some of the benefits include:

- Reduction of copper consumption
- Fewer safety risks for workers
- Lower labor handling costs
- Greater conductor efficiency
- Ability to run higher power loads.

## **4.8 Electrical transmission**

Electrical transmission is the process of delivering generated electricity - usually over long distances - to the distribution grid located in populated areas. An important part of this process includes transformers, which are used to increase voltage levels to make long distance transmission feasible.

The electrical transmission system is used in combination with power plants, distribution systems, and sub-stations to form what is known as the electrical grid. The grid is designed to meet all of society's electricity needs, and is what gets the electrical power from its beginning to its end use. Since power plants are most often located outside of densely populated areas, the transmission system must be large.



**FIGURE 4.3.** High voltage power lines are used for the transmission of electricity over long distances.

Very high voltages are used for transmission systems because, as a general principle, the higher the voltage the cheaper is the supply. Since power in an a.c. system is expressed as  $P = VI \cos \theta$ , it follows that an increase in voltage will reduce the current for a given amount of power. A lower current will result in reduced cable and switchgear size and the line power losses, given by the equation  $P = I^2R$ , will also be reduced.

The 132 kV grid and 400 kV super grid transmission lines are, for the most part, steel-cored aluminium conductors suspended on steel lattice towers.

### **Power Lines**

Power lines or transmission lines, such as those in **Figure 4.3**, are used to transport electricity from place to place. This electricity is in the form of alternating current and begins at step-up transformers, and typically span a distance of 500 kilometers or less. There are 3 types of lines:

- Overhead lines are very high voltage, between 100 kV and 800 kV, and do the majority of long distance transmission. They must be high voltage in order to minimize power losses to resistance.
- Underground lines are used to transport power through populated areas, underwater, or anywhere that overhead lines cannot be used. They are less common than overhead lines due to heat-related losses and higher cost.
- Sub transmission lines carry lower voltages (26 kV - 69 kV) to distribution stations, and can be overhead or underground.

### **Distribution systems**

Primary distribution to consumers is from 11 kV substations, which for the most part are fed from 33 kV substations, but direct transformation between 132 and 11 kV is becoming common policy in city areas where over 100 MW can be economically distributed at 11 kV from one site.

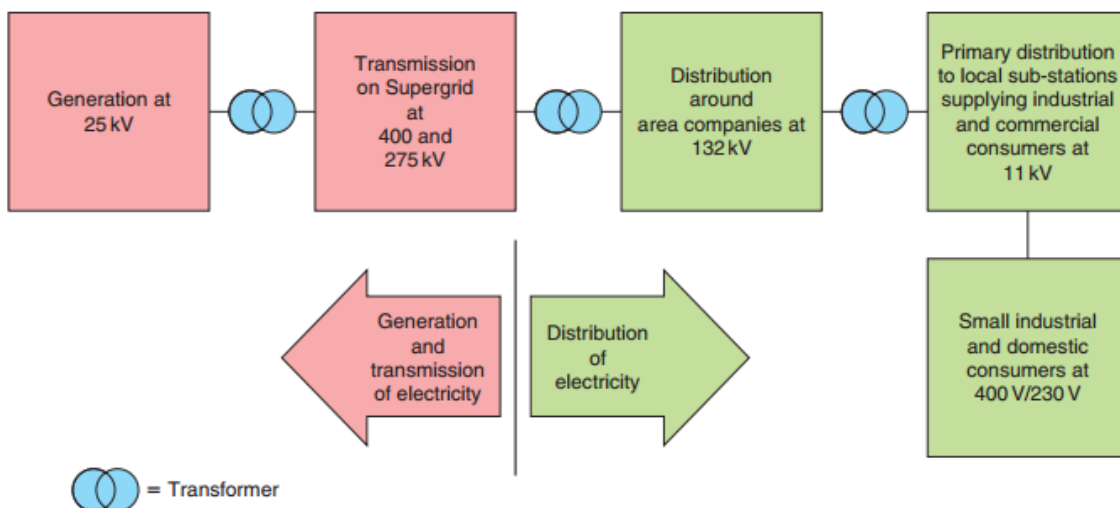

Figure 4.4 shows a block diagram indicating the voltages at the various stages of the transmission and distribution system and Fig. 4.5 shows a simplified diagram of the transmission and distribution of electricity to the consumer.

Distribution systems at 11 kV may be ring or radial systems but a ring system offers a greater security of supply. The maintenance of a secure supply is an important consideration for any electrical engineer or supply authority because electricity plays a vital part in an industrial society, and a loss of supply may cause inconvenience, financial loss or danger to the consumer or the public.

The principle employed with a ring system is that any consumer's substation is fed from two directions, and by carefully grading the overload and cable protection equipment a fault can be disconnected without loss of supply to other consumers.

High-voltage distribution to primary substations is used by the electricity boards to supply small industrial, commercial and domestic consumers. This distribution method is also suitable for large industrial consumers where 11 kV substations, as shown in Fig. 4.8 may be strategically placed at load centres around the factory site.



**FIGURE 4.4.** Generation, transmission and distribution of electrical energy.

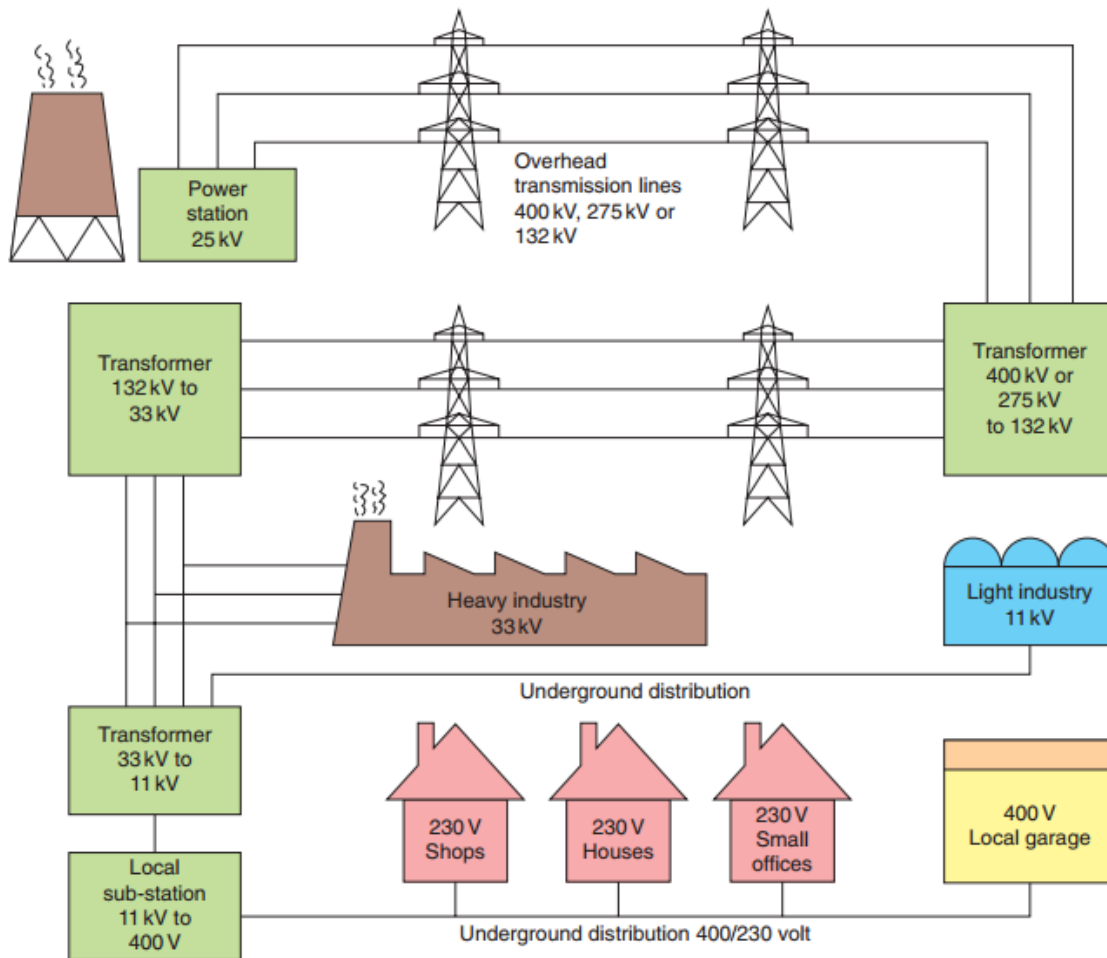

**FIGURE 4.5:** Simplified diagram of distribution of electricity from power station to consumer

**\*National Grid:** The National Grid is a network of some 5000 miles of overhead and underground power cables.

Figure 4.6 shows a suspension tower on the National Grid network. The conductors are attached to porcelain insulator strings which are fixed to the cross-members of the tower as shown in Fig. 4.7. Three conductors comprise a single circuit of a three-phase system so that towers with six arms carry two separate circuits



**FIGURE 4.6:** Suspension tower

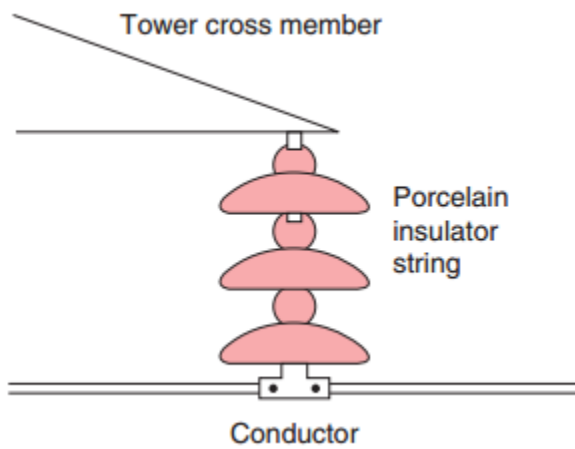

**FIGURE 4.7:** Steel lattice tower cable supports.

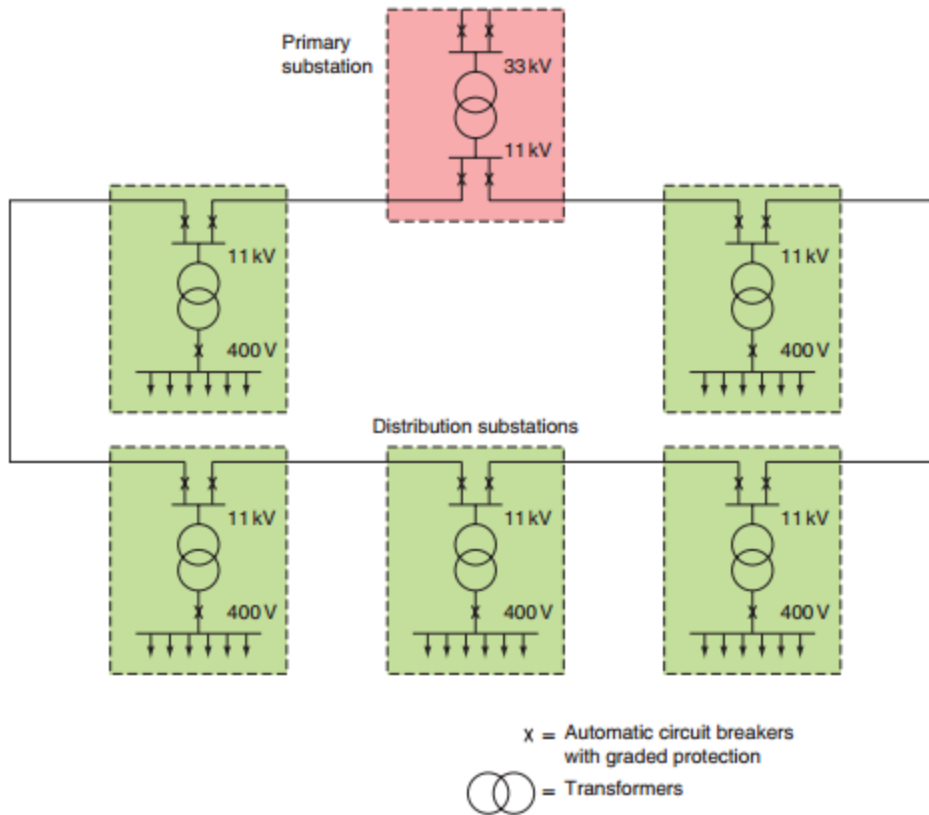

**FIGURE 4.8.**High-voltage ring main distribution.

The final connections to plant, distribution boards, commercial or domestic loads are usually by simple underground radial feeders at 400 V/230 V.

In towns and cities the substation equipment is usually enclosed in a brick building, as shown in Fig. 4.9

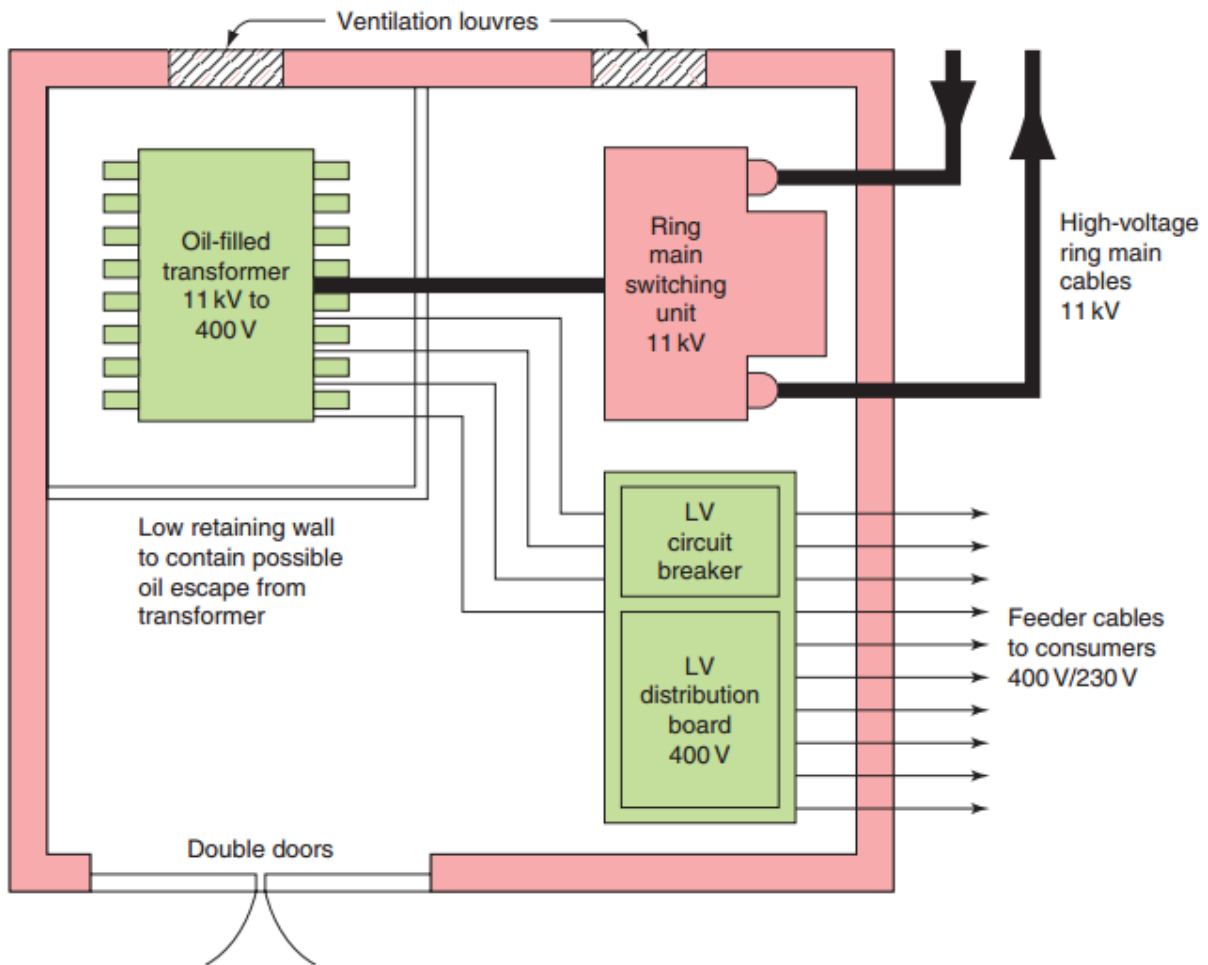

**FIGURE 4.9.** Typical sub-station layout.

These outgoing circuits are usually protected by circuit breakers in a distribution board.

The 400 V/230 V is derived from the 11 kV/400 V sub-station transformer by connecting the secondary winding in star as shown in Fig. 5.7. The star point is earthed to an earth electrode sunk into the ground below the sub-station, and from this point is taken the fourth conductor, the neutral. Loads connected between phases are fed at 400 V, and those fed between one phase and neutral at 230 V. A three-phase 400 V supply is used for supplying small industrial and commercial loads such as garages, schools and blocks of flats. A single-phase 230 V supply is usually provided for individual domestic consumers.

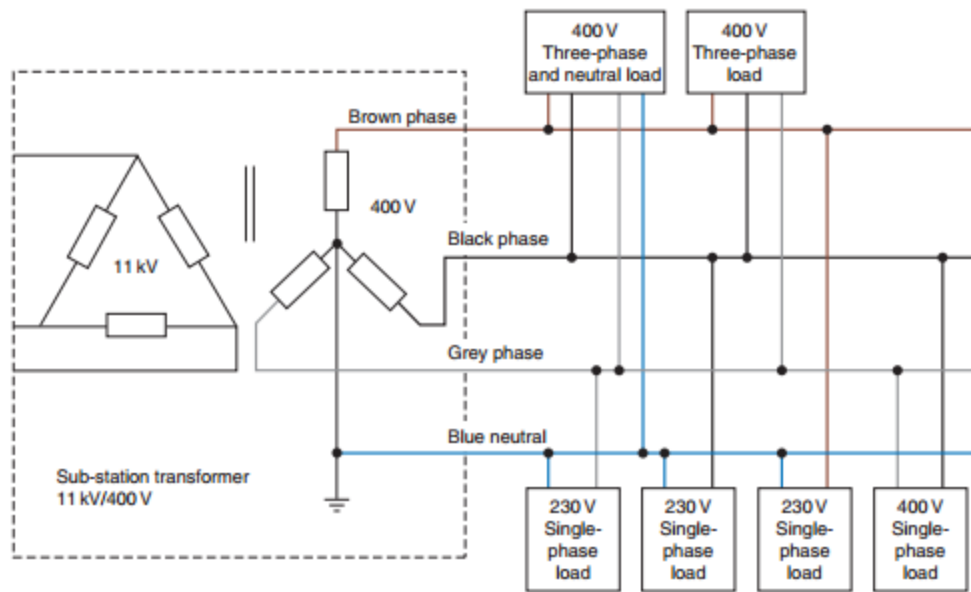

**FIGURE 5.7:** Three-phase four-wire distribution.