

Lecture Two: Electrical Power generation

The design of a power plant should incorporate two important aspects.

- The selection and placing of necessary power-generating equipment should be such so that a maximum of return will result from a minimum of expenditure over the working life of the plant.
- The operation of the plant should be such so as to provide cheap, reliable and continuous service.

2.1 Generating Stations

Bulk electric power is produced by special plants known as generating stations or power plants.

A generating station essentially employs a prime mover coupled to an alternator for the production of electric power. The prime mover (e.g. Steam turbine, water turbine etc.) converts energy from some other form into mechanical energy. The alternator converts mechanical energy of the prime mover into electrical energy. The electrical energy produced by the generating station is transmitted and distributed with the help of conductors to various consumers.

Depending upon the form of energy converted into electrical energy, the generating stations are classified as under:

- i. Steam power stations
- ii. Hydroelectric power stations
- iii. Diesel power stations
- iv. Nuclear power stations

2.2 Steam Power Station (Thermal Station)

It is a generating station which converts heat energy of coal combustion into electrical energy.

A steam power station basically works on the **Rankine cycle**. Steam is produced in the boiler by utilizing the heat of coal combustion. The steam is then expanded in the prime mover (*i.e.*, steam turbine) and is condensed in a condenser to be fed into the boiler again. The steam turbine drives the alternator which converts mechanical energy of the turbine into electrical energy. This type of power station is suitable where coal and water are available in abundance and a large amount of electric power is to be generated.

Advantages

- i. The fuel (*i.e.*, coal) used is quite cheap.
- ii. Less initial cost as compared to other generating stations.
- iii. It can be installed at any place irrespective of the existence of coal. The coal can be transported to the site of the plant by rail or road.
- iv. It requires less space as compared to the hydroelectric power station.

- v. The cost of generation is lesser than that of the diesel power station.

Disadvantages

- i. It pollutes the atmosphere due to the production of large amount of smoke and fumes.
- ii. It is costlier in running cost as compared to hydroelectric plant.

2.3 Choice of Site for Steam Power Stations

In order to achieve overall economy, the following points should be considered while selecting a site

for a steam power station :

(i) Supply of fuel. The steam power station should be located near the coal mines so that transportation cost of fuel is minimum. However, if such a plant is to be installed at a place where coal is not available, then care should be taken that adequate facilities exist for the transportation of coal.

(ii) Availability of water. As huge amount of water is required for the condenser, therefore, such a plant should be located at the bank of a river or near a canal to ensure the continuous supply of water.

(iii) Transportation facilities. A modern steam power station often requires the transportation of material and machinery. Therefore, adequate transportation facilities must exist *i.e.*, the plant should be well connected to other parts of the country by rail, road. etc.

(iv) Cost and type of land. The steam power station should be located at a place where land is cheap and further extension, if necessary, is possible. Moreover, the bearing capacity of the ground should be adequate so that heavy equipment could be installed.

(v) Nearness to load centres. In order to reduce the transmission cost, the plant should be located near the centre of the load. This is particularly important if *d.c* supply system is adopted. However, if *a.c.* supply system is adopted, this factor becomes relatively less important. It is because *a.c.* power can be transmitted at high voltages with consequent reduced transmission cost. Therefore, it is possible to install the plant away from the load centres, provided other conditions are favorable.

(vi) Distance from populated area. As huge amount of coal is burnt in a steam power station, therefore, smoke and fumes pollute the surrounding area. This necessitates that the plant should be located at a considerable distance from the populated areas.

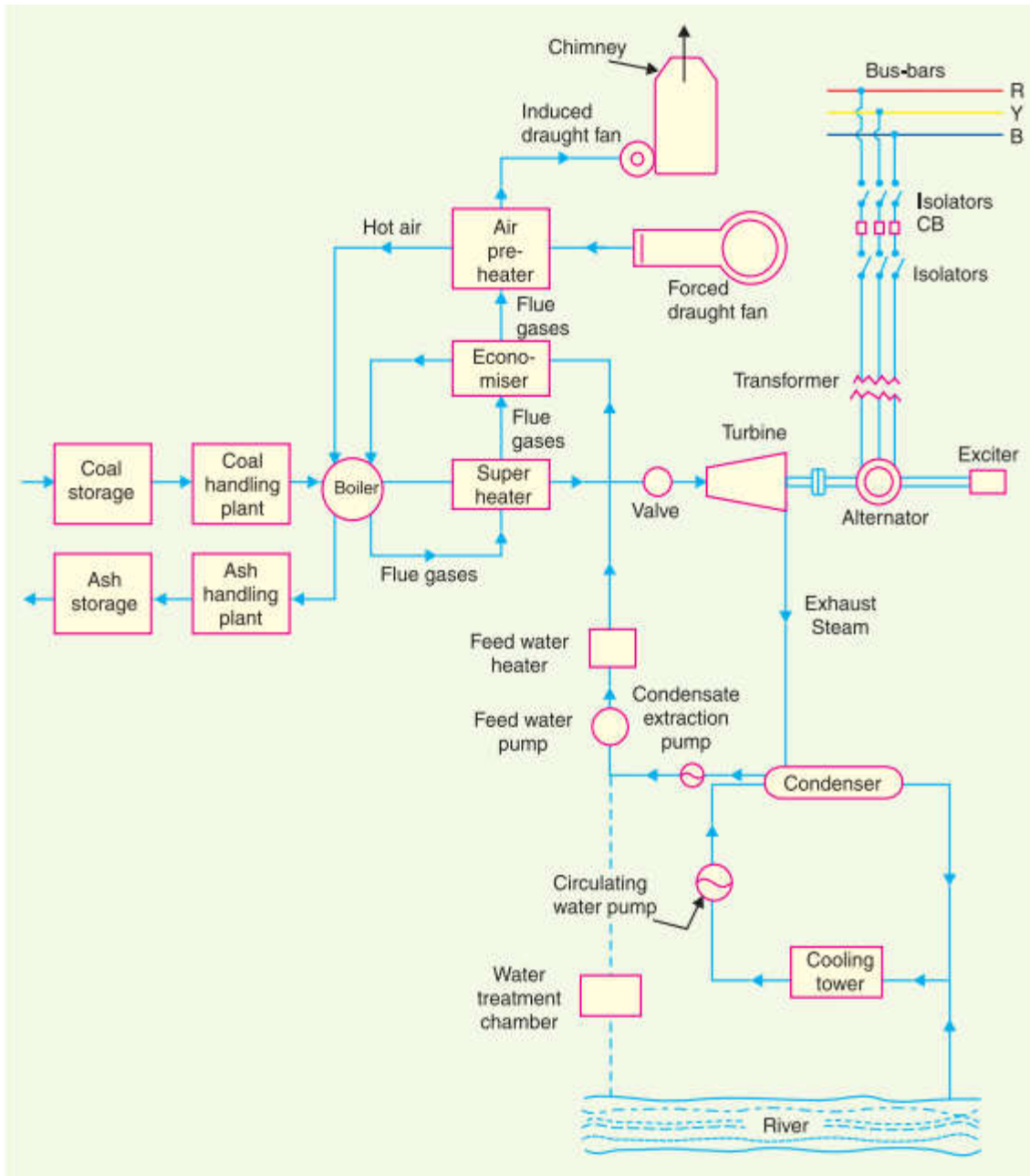

Schematic arrangement of a steam power plant

2.4 Hydro-electric Power Station

Is generating station which utilizes the potential energy of water at a high level for the generation of electrical energy.

Hydro-electric power stations are generally located in hilly areas where dams can be built conveniently and large water reservoirs can be obtained. In a hydro-electric power station, water head is created by constructing a dam across a river or lake. From the dam, water is led to a water turbine.

The water turbine captures the energy in the falling water and changes the hydraulic energy (*i.e.*, product of head and flow of water) into mechanical energy at the turbine shaft. The turbine drives the alternator which converts mechanical energy into electrical energy. Hydro-electric power stations are becoming very popular because the reserves of fuels (*i.e.*, coal and oil) are depleting day by day.

Advantages

- (i)** It requires no fuel as water is used for the generation of electrical energy.
- (ii)** It is quite neat and clean as no smoke or ash is produced.
- (iii)** It requires very small running charges because water is the source of energy which is available free of cost.
- (iv)** It is comparatively simple in construction and requires less maintenance.
- (v)** It does not require a long starting time like a steam power station. In fact, such plants can be put into service instantly.
- (vi)** It is robust and has a longer life.
- (vii)** Such plants serve many purposes. In addition to the generation of electrical energy, they also help in irrigation and controlling floods.
- (viii)** Although such plants require the attention of highly skilled persons at the time of construction, yet for operation, a few experienced persons may do the job well.

Disadvantages

- (i)** It involves high capital cost due to construction of dam.
- (ii)** There is uncertainty about the availability of huge amount of water due to dependence on weather conditions.
- (iii)** Skilled and experienced hands are required to build the plant.
- (iv)** It requires high cost of transmission lines as the plant is located in hilly areas which are quite away from the consumers.

2.5 Choice of Site for Hydro-Electric Power Stations

(i) Availability of water. Since the primary requirement of a hydro-electric power station is the availability of huge quantity of water, such plants should be built at a place (*e.g.*, river, canal) where adequate water is available at a good head.

(ii) Storage of water. There are wide variations in water supply from a river or canal during the year. This makes it necessary to store water by constructing a dam in order to ensure the generation of power throughout the year. The storage helps in equalizing the flow of water so that any excess quantity of water at a certain period of the year can be made available

during times of very low flow in the river. This leads to the conclusion that site selected for a hydro-electric plant should provide adequate facilities for erecting a dam and storage of water.

(iii) Cost and type of land. The land for the construction of the plant should be available at a reasonable price. Further, the bearing capacity of the ground should be adequate to withstand the weight of heavy equipment to be installed.

(iv) Transportation facilities. The site selected for a hydro-electric plant should be accessible by rail and road so that necessary equipment and machinery could be easily transported.

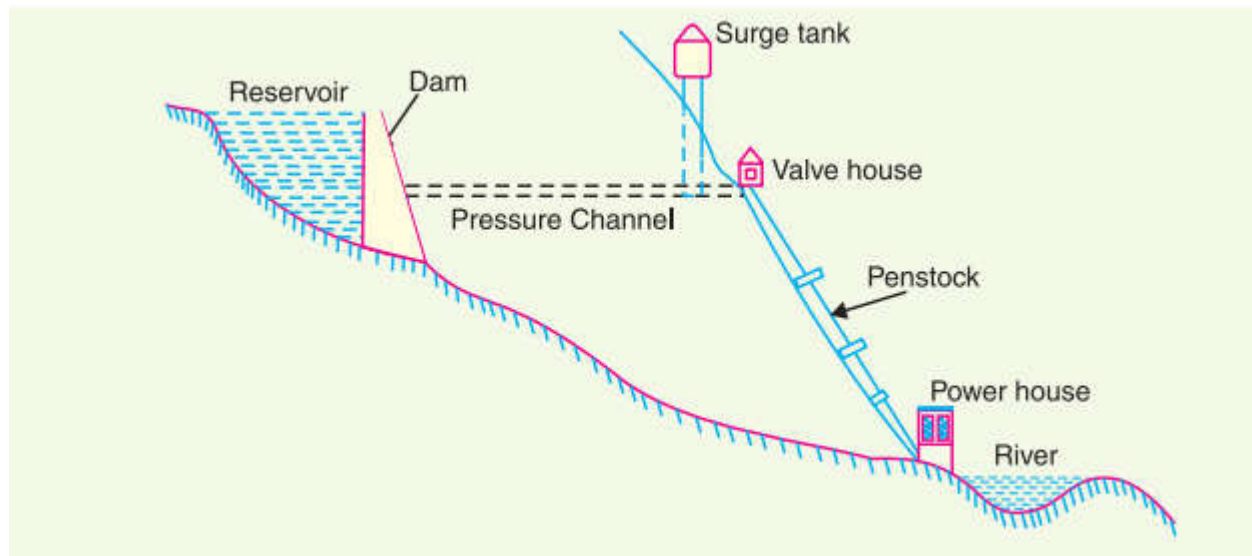

Schematic Arrangement of a Hydro-electric plant

2.6 Diesel Power Station

Is a generating station in which diesel engine is used as the prime mover for the generation of electrical energy.

In a diesel power station, diesel engine is used as the prime mover. The diesel burns inside the engine and the products of this combustion act as the “working fluid” to produce mechanical energy.

The diesel engine drives the alternator which converts mechanical energy into electrical energy. As the generation cost is considerable due to high price of diesel, therefore, such power stations are only used to produce small power.

Advantages

(i) The design and layout of the plant are quite simple.

(ii) It occupies less space as the number and size of the auxiliaries is small.

- (iii) It can be located at any place.
- (iv) It can be started quickly and can pick up load in a short time.
- (v) There are no standby losses.
- (vi) It requires less quantity of water for cooling.
- (vii) The overall cost is much less than that of steam power station of the same capacity.
- (viii) The thermal efficiency of the plant is higher than that of a steam power station.
- (ix) It requires less operating staff.

Disadvantages

- (i) The plant has high running charges as the fuel (*i.e.*, diesel) used is costly.
- (ii) The plant does not work satisfactorily under overload conditions for a longer period.
- (iii) The plant can only generate small power.
- (iv) The cost of lubrication is generally high.
- (v) The maintenance charges are generally high.

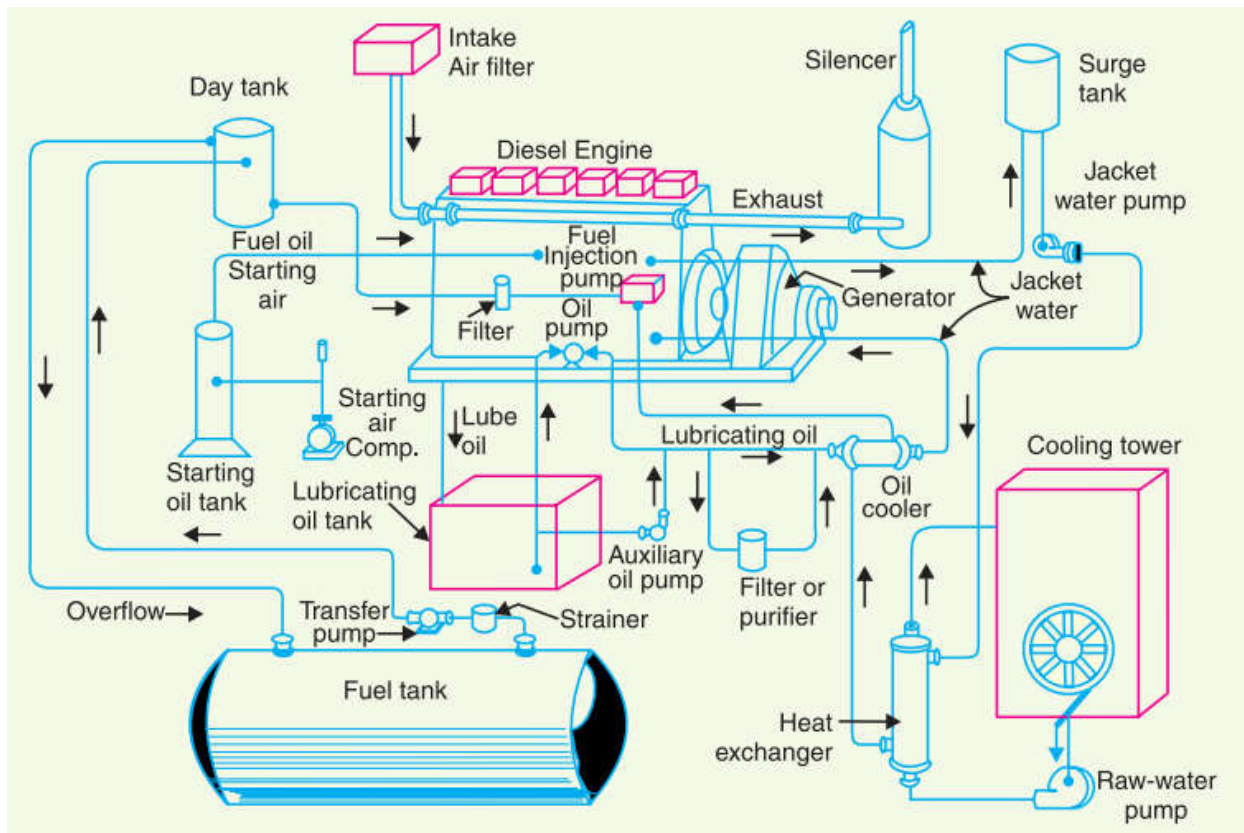

Schematic Arrangement of a Diesel Power Station

2.7 Nuclear Power Station

It is a generating station in which nuclear energy is converted into electrical energy.

In nuclear power station, heavy elements such as Uranium (U^{235}) or Thorium (Th^{232}) are subjected to nuclear fission in a special apparatus known as a *reactor*. The heat energy thus released is utilized in raising steam at high temperature and pressure. The steam runs the steam turbine which converts steam energy into mechanical energy. The turbine drives the alternator which converts mechanical energy into electrical energy.

The most important feature of a nuclear power station is that huge amount of electrical energy can be produced from a relatively small amount of nuclear fuel as compared to other conventional types of power stations.

Advantages

- (i) The amount of fuel required is quite small. Therefore, there is a considerable saving in the cost of fuel transportation.
- (ii) A nuclear power plant requires less space as compared to any other type of the same size.
- (iii) It has low running charges as a small amount of fuel is used for producing bulk electrical energy.
- (iv) This type of plant is very economical for producing bulk electric power.
- (v) It can be located near the load centres because it does not require large quantities of water and need not be near coal mines. Therefore, the cost of primary distribution is reduced.
- (vi) There are large deposits of nuclear fuels available all over the world. Therefore, such plants can ensure continued supply of electrical energy for thousands of years.
- (vii) It ensures reliability of operation.

Disadvantages

- (i) The fuel used is expensive and is difficult to recover.
- (ii) The capital cost on a nuclear plant is very high as compared to other types of plants.
- (iii) The erection and commissioning of the plant requires greater technical know-how.
- (iv) The fission by-products are generally radioactive and may cause a dangerous amount of radioactive pollution.
- (v) Maintenance charges are high due to lack of standardization. Moreover, high salaries of specially trained personnel employed to handle the plant further raise the cost.
- (vi) Nuclear power plants are not well suited for varying loads as the reactor does not respond to the load fluctuations efficiently.
- (vii) The disposal of the by-products, which are radioactive, is a big problem. They have either to be disposed off in a deep trench or in a sea away from sea-shore.

2.8 Selection of Site for Nuclear Power Station

(i) *Availability of water.* As sufficient water is required for cooling purposes, therefore, the plant site should be located where ample quantity of water is available, e.g., across a river or by sea-side.

(ii) *Disposal of waste.* The waste produced by fission in a nuclear power station is generally radioactive which must be disposed off properly to avoid health hazards. The waste should either be buried in a deep trench or disposed off in sea quite away from the sea shore. Therefore, the site selected for such a plant should have adequate arrangement for the disposal of radioactive waste.

(iii) *Distance from populated areas.* The site selected for a nuclear power station should be quite away from the populated areas as there is a danger of presence of radioactivity in the atmosphere near the plant. However, as a precautionary measure, *a dome* is used in the plant which does not allow the radioactivity to spread by wind or underground waterways.

(iv) *Transportation facilities.* The site selected for a nuclear power station should have adequate facilities in order to transport the heavy equipment during erection and to facilitate the movement of the workers employed in the plant.

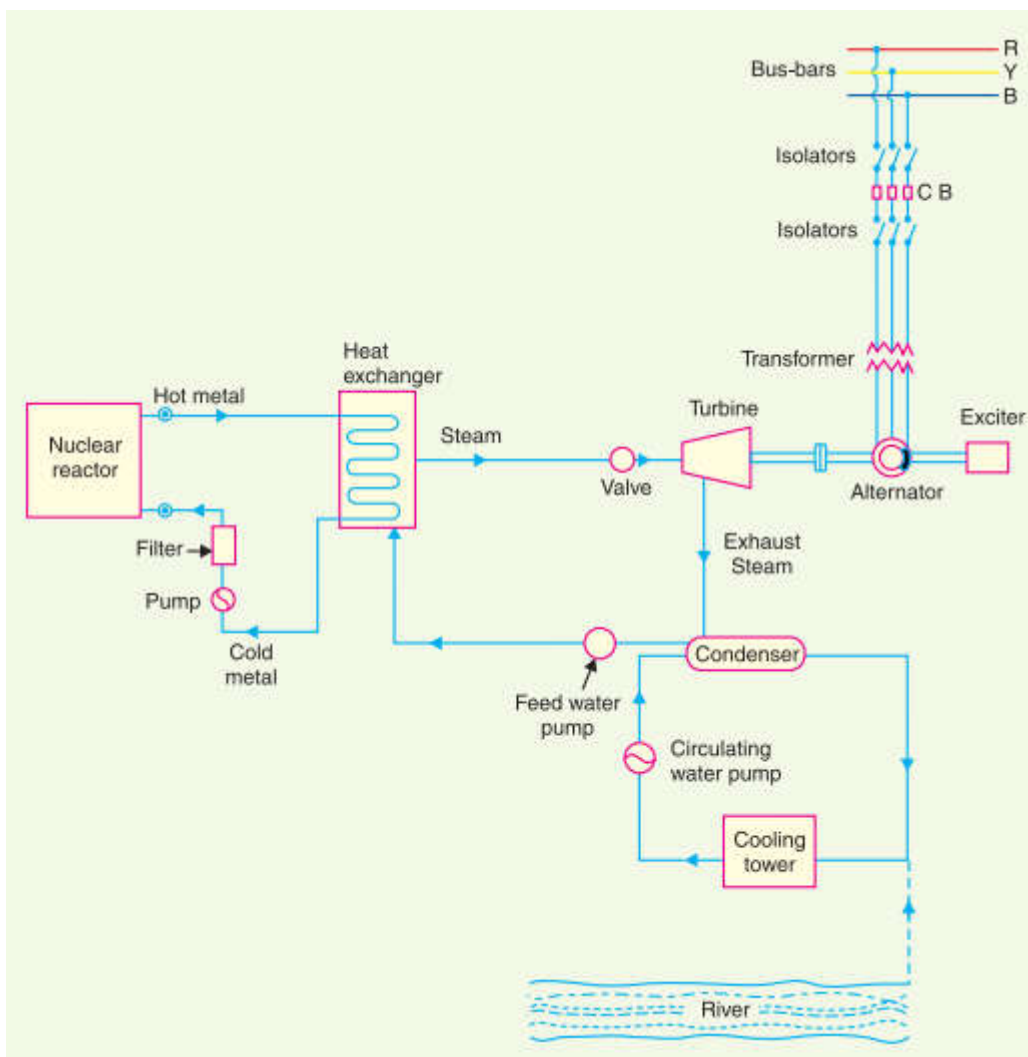

Schematic Arrangement of a Nuclear Power Station

2.8 Gas Turbine Power Plant

It is a generating station which employs gas turbine as the prime mover for the generation of electrical energy.

In a gas turbine power plant, air is used as the working fluid. The air is compressed by the compressor and is led to the combustion chamber where heat is added to air, thus raising its temperature. Heat is added to the compressed air either by burning fuel in the chamber or by the use of air heaters. The hot and high pressure air from the combustion chamber is then passed to the gas turbine where it expands and does the mechanical work. The gas turbine drives the alternator which converts mechanical energy into electrical energy.

Advantages

- (i)** It is simple in design as compared to steam power station since no boilers and their auxiliaries are required.
- (ii)** It is much smaller in size as compared to steam power station of the same capacity. This is expected since gas turbine power plant does not require boiler, feed water arrangement etc.
- (iii)** The initial and operating costs are much lower than that of equivalent steam power station.
- (iv)** It requires comparatively less water as no condenser is used.
- (v)** The maintenance charges are quite small.
- (vi)** Gas turbines are much simpler in construction and operation than steam turbines.
- (vii)** It can be started quickly from cold conditions.
- (viii)** There are no standby losses. However, in a steam power station, these losses occur because boiler is kept in operation even when the steam turbine is supplying no load.

Disadvantages

- (i)** There is a problem for starting the unit. It is because before starting the turbine, the compressor has to be operated for which power is required from some external source. However, once the unit starts, the external power is not needed as the turbine itself supplies the necessary power to the compressor.
- (ii)** Since a greater part of power developed by the turbine is used in driving the compressor, the net output is low.
- (iii)** The overall efficiency of such plants is low (about 20%) because the exhaust gases from the turbine contain sufficient heat.
- (iv)** The temperature of combustion chamber is quite high (3000oF) so that its life is comparatively reduced.

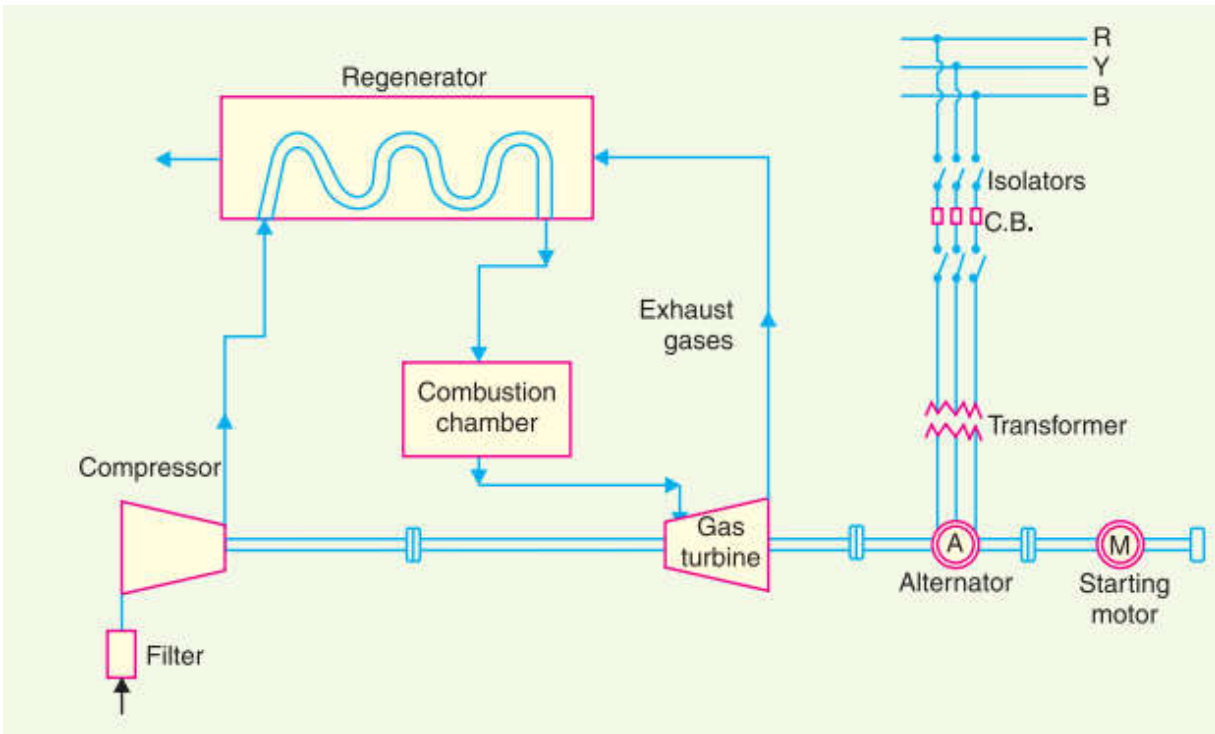

Schematic arrangement of gas turbine power

2.9 Comparison of the various power plants

Item	Steam Power Station	Hydro-electric Power Plant	Diesel Power Plant	Nuclear power Plant
1. Site	Such plants are located at a place where ample supply of water and coal is available, transportation facilities are adequate	Such plants are located where large reservoirs can be obtained by constructing a dam e.g. in hilly areas	Such plants can be located at any place because they require less space and small quantity of water	These plants are located away from thickly populated areas to avoid radioactive pollution
2. Initial cost	Initial cost is lower than those of hydroelectric and nuclear power plants	Initial cost is very high because of dam construction and excavation work.	Initial cost is less as compared to other plants.	Initial cost is highest because of huge investment on building a nuclear reactor
3. Running cost	Higher than hydroelectric and nuclear plant because of the requirement of huge amount of coal	Practically nil because no fuel is required	Highest among all plants because of high price of diesel.	Except the hydroelectric plant, it has the minimum running cost because small amount of fuel can produce relatively large amount of power

Item	Steam Power Station	Hydro-electric Power Plant	Diesel Power Plant	Nuclear power Plant
4. Limit of source of power	Coal is the source of power which has limited reserves all over the world.	Water is the source of power which is not dependable because of wide variations in the rainfall every year	Diesel is the source of power which is not available in huge quantities due to limited reserves.	The source of power is the nuclear fuel which is available in sufficient quantity. It is because small amount of fuel can produce huge power
5. Cost of fuel transportation	Maximum because huge amount of coal is transported to the plant site	Practically nil.	Higher than hydro and nuclear power plants	Minimum because small quantity of fuel is required.
6. Cleanliness and simplicity	Least clean as atmosphere is polluted due to smoke.	Most simple and clean	More clean than steam power and nuclear power plants	Less cleaner than hydroelectric and diesel power plants
7. Overall efficiency	Least efficient. Overall efficiency is about 25%	Most efficient. Overall efficiency is about 85%.	More efficient than steam power station. Efficiency is about 35%	More efficient than steam power station.
8. Starting	Requires a lot of time for starting	Can be started instantly	Can be started quickly	Can be started easily
9. Space required	These plants need sufficient space because of boilers and other auxiliaries	Require very large area because of the reservoir	Require less space	These require minimum space as compared to any other plant of equivalent capacity
10. Maintenance cost	Quite high as skilled operating staff is required.	Quite low	Less	Very high as highly trained personnel are required to handle the plant
11. Transmission and distribution cost	Quite low as these are generally located near the load centres	Quite high as these are located quite away from the load centres	Least as they are generally located at the centre of gravity of the load	Quite low as these are located near load centres.
12. Standby Losses	Maximum as the boiler remains in operation even when the turbine is not working	No standby losses.	Less standby losses.	Less.