

LECTURE 3: Physical Realization of Compensation

Compensators can either be active PI, PD, or PID controllers or passive lag, lead, or lag-lead compensators.

3.1 Active-Circuit Realization

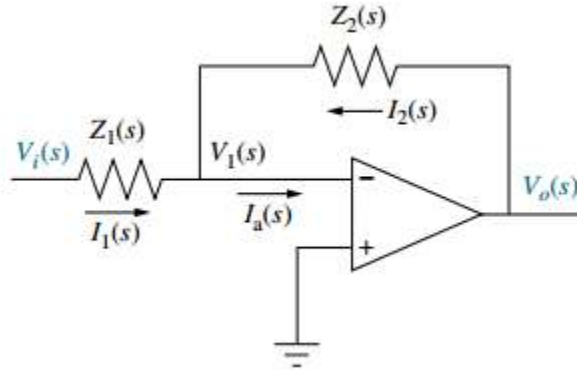

Figure 3.1 Operational amplifier configured for transfer function realization

The transfer function of an inverting operational amplifier shown above is;

$$\frac{V_o(s)}{V_i(s)} = -\frac{Z_2(s)}{Z_1(s)}$$

By judicious choice of $Z_1(s)$, and $Z_2(s)$, this circuit can be used as a building block to implement the compensators and controllers, such as PID controllers. Other compensators can be realized by cascading compensators shown in the table. For example, a lag-lead compensator can be formed by cascading the lag compensator with the lead compensator as shown in figure 3.2.

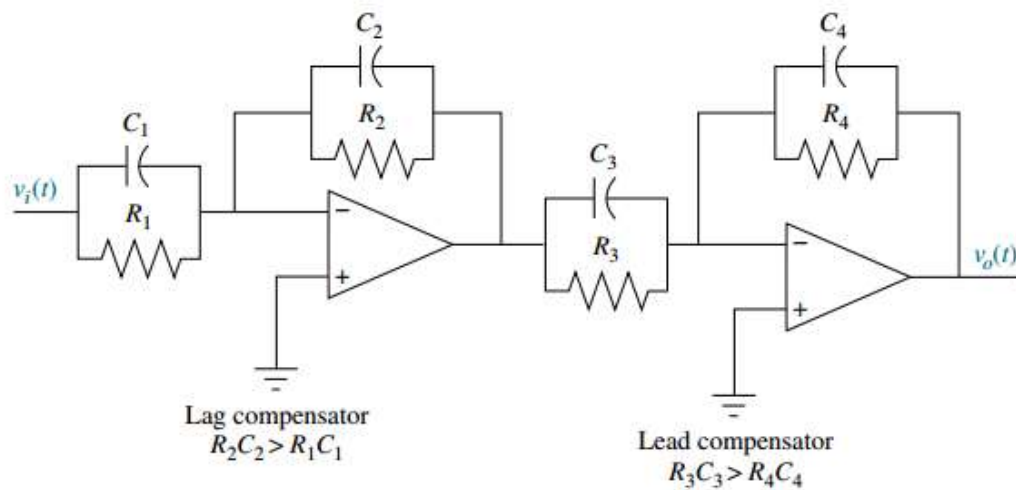

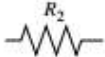



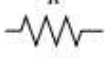
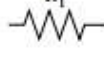
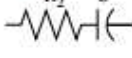
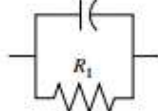
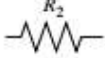
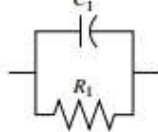

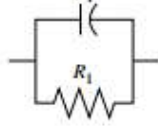
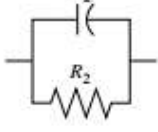
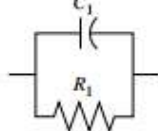
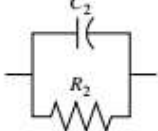

Figure 3.2 Lag-lead compensator implemented with operational amplifiers

Table 3.1 Active realization of controllers and compensators, using an operational amplifier

Function	$Z_1(s)$	$Z_2(s)$	$G_c(s) = -\frac{Z_2(s)}{Z_1(s)}$
Gain			$-\frac{R_2}{R_1}$
Integration			$-\frac{1}{RCs}$
Differentiation			$-RCs$
PI controller			$-\frac{R_2}{R_1} \left(s + \frac{1}{R_2 C} \right)$
PD controller			$-R_2 C \left(s + \frac{1}{R_1 C} \right)$
PID controller			$-\left[\left(\frac{R_2}{R_1} + \frac{C_1}{C_2} \right) + R_2 C_1 s + \frac{1}{R_1 C_2} \right]$
Lag compensation			$-\frac{C_1}{C_2} \left(\frac{s + \frac{1}{R_1 C_1}}{s + \frac{1}{R_2 C_2}} \right)$ where $R_2 C_2 > R_1 C_1$
Lead compensation			$-\frac{C_1}{C_2} \left(\frac{s + \frac{1}{R_1 C_1}}{s + \frac{1}{R_2 C_2}} \right)$ where $R_1 C_1 > R_2 C_2$

3.2 Implementing a PID Controller

Implement the PID controller whose transfer function is;

$$G_c(s) = \frac{(s + 55.92)(s + 0.5)}{s}$$

Solution;

The equation can be put in the form;

$$G_c(s) = s + 56.42 + \frac{27.96}{s}$$

Comparing the PID controller in Table 3.1 with the equation above, we obtain the following three relationships;

$$\frac{R_2}{R_1} + \frac{C_1}{C_2} = 56.42$$

$$R_2 C_1 = 1$$

$$\frac{1}{R_1 C_2} = 27.96$$

Since there are four unknowns and three equations, we arbitrarily select a practical value for one of the elements. Selecting $C_2=0.1\mu\text{F}$, the remaining values are found to be $R_1 = 357.65\text{k}\Omega$, $R_2 = 78.891\text{k}\Omega$, and $C_1=5.59\mu\text{F}$.

The complete circuit;

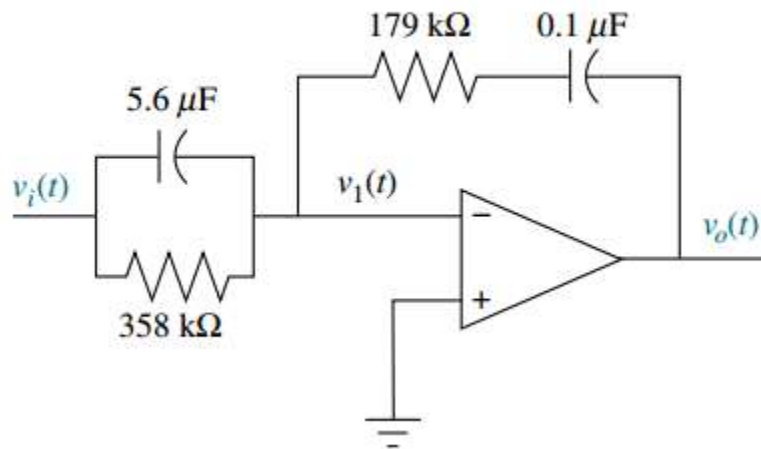

Figure 3.3 PID controller

3.3 Passive-Circuit Realization

Lag, lead, and lag-lead compensators can also be implemented with passive networks.

The lag-lead transfer function can be put in the following form;

$$G_c(s) = \frac{\left(s + \frac{1}{T_1}\right)\left(s + \frac{1}{T_2}\right)}{\left(s + \frac{1}{\alpha T_1}\right)\left(s + \frac{\alpha}{T_2}\right)}$$

Where $\alpha < 1$. Thus, the terms with T_1 form the lead compensator, and the terms with T_2 form the lag compensator. The above equation shows a restriction inherent in using this passive realization. We see that the ratio of the lead compensator zero to the lead compensator pole must be the same as the ratio of the lag compensator pole to the lag compensator zero.

A lag-lead compensator without this restriction can be realized with an active network or with passive networks by cascading the lead and lag networks shown in the table 3.2 below. Remember, though, that the two networks must be isolated to ensure that one network does not load the other. If the networks load each other, the transfer function will not be the product of the individual transfer functions. A possible realization using the passive networks uses an operational amplifier to provide isolation.

Table 3.2 Passive realization of compensators

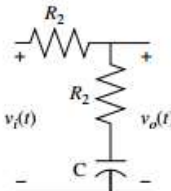
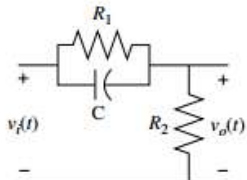
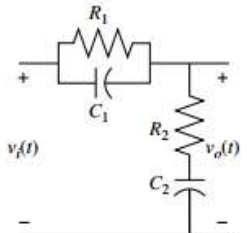
Function	Network	Transfer function, $\frac{V_o(s)}{V_i(s)}$
Lag compensation		$\frac{R_2}{R_1 + R_2} \frac{s + \frac{1}{R_2 C}}{s + \frac{1}{(R_1 + R_2) C}}$
Lead compensation		$\frac{s + \frac{1}{R_1 C}}{s + \frac{1}{R_1 C} + \frac{1}{R_2 C}}$
Lag-lead compensation		$\frac{\left(s + \frac{1}{R_1 C_1}\right)\left(s + \frac{1}{R_2 C_2}\right)}{s^2 + \left(\frac{1}{R_1 C_1} + \frac{1}{R_2 C_2} + \frac{1}{R_2 C_1}\right)s + \frac{1}{R_1 R_2 C_1 C_2}}$

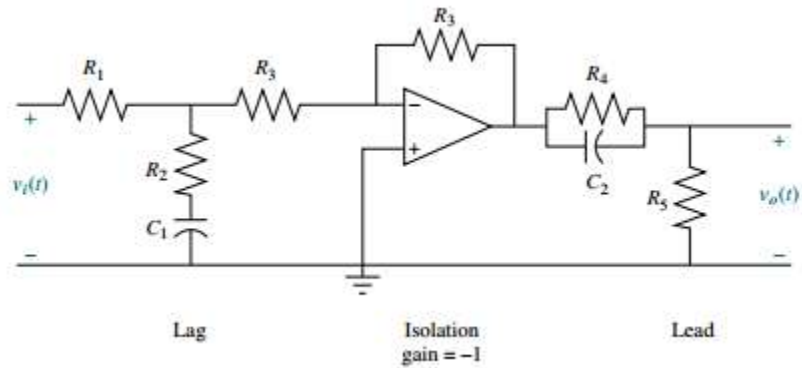

Figure 3.3 Lag-lead compensator implemented with cascaded lag and lead networks with isolation

3.4 Realizing a Lead Compensator

Realize the lead compensator whose transfer function is;

$$G_c(s) = \frac{s + 4}{s + 20.09}$$

Comparing the transfer function of a lead network shown in Table 3.2 with the above equation, we obtain the following two relationships:

$$\frac{1}{R_1 C} = 4$$

And

$$\frac{1}{R_1 C} + \frac{1}{R_2} = 20.09$$

Hence,

Hence, $R_1 C = 0.25$, and $R_2 C = 0.0622$. Since there are three network elements and two equations, we may select one of the element values arbitrarily.

Letting

$C = 1\mu\text{F}$, then $R_1 = 250\text{ k}\Omega$ and $R_2 = 62.2\text{ k}\Omega$.